



Prism Healthcare Equipment Guide

April 2023
www.prismhealthcare.co.uk

MAKING
CARE EASIER

PRISM HEALTHCARE
YOUR FIRST CHOICE...

prismhealthcare

CHOICE IS EVERYTHING

At Prism Healthcare, our mission is to transform the quality of life of people with health and mobility conditions by providing solutions which offer choice, value for money and help to make care delivery easier.

We offer a diverse portfolio of UK manufactured equipment, including safe patient handling, bathing, accessibility and pressure area care products. Our products provide healthcare professionals with affordable, clinically effective solutions to help disabled and mobility disadvantaged people to live life to the full with dignity whether living at home, in long-term care facilities or in acute care environments.

We help healthcare professionals to provide the best client care.

PRISM HEALTHCARE FAMILY

prismmedicaluk
a prismhealthcare company

smirthwaite
a prismhealthcare company

harvesthealthcare
a prismhealthcare company

Repose
Specialist Seating Solutions
a prismhealthcare company



TOTAL SUPPORT TEAM

We offer the full support package from design, manufacture, assessment and installation, through to maintenance service.



FAST TRACK NATIONWIDE DELIVERY

Our own transport fleet gives us the flexibility to meet your needs. We also have access to our Prism partners to deliver directly to your door.



SUPERIOR BUILD QUALITY

Our UK manufacturing sites are ISO accredited, with a skilled workforce following robust processes.



KNOWLEDGEABLE TEAM

Our experienced Assessors and Sales team are always available to help you find the best possible solution.



INNOVATIVE WELL DESIGNED PRODUCTS

Our UK design and manufacturing capability enables us to respond to the ever-changing needs of our customers.



EXCEPTIONAL VALUE FOR MONEY

Locally sourced raw materials and in-house design allows us to provide you with cost-effective products and services.



EXTENSIVE OFFERING

To offer you the best, flexible solution we maintain an extensive range of products and services within the industry.



www.prismhealthcare.co.uk

Unit 4, Jubilee Business Park, Jubilee Way, Grange Moor, Wakefield, WF4 4TD
T +44 (0)1924 840100 E info@prismmedical.co.uk

CONTENTS

Here to Help	03
1. Beds	04
1.1. Woburn Profiling Beds	05
1.2. Elita Profiling Beds	14
1.3. Bed Accessories	21
1.4. Bed Bumpers	27
2. Mattresses and Cushions	34
2.1. Static Mattresses	35
2.2. Hybrid Mattresses	47
2.3. Active Mattresses	49
2.4. Pumps	60
2.5. Fall Mats, Underlays and Overlays	61
2.6. Cushions	62
3. Positioning Aids	75
4. Fall Reduction	90
5. Moving and Handling	94
5.1. Stand Aids, Hoists and Transfer Aids	95
5.2. Ceiling Track Hoists	103
5.3. Slings	109
5.4. Bed Management Systems	126
5.5. Wheelchairs	130
6. Showering and Toilet Aids	132
7. Evacuation Products	142
8. Repose Specialist Seating	146

HERE TO HELP



HEAD OFFICE

Prism Healthcare

Unit 4, Jubilee Business Park
Jubilee Way
Grange Moor
Wakefield
WF4 4TD

T +44 (0)1924 840100

E contact@prismhealthcare.co.uk

www.prismhealthcare.co.uk

FOR MORE INFORMATION VISIT WWW.PRISMHEALTHCARE.CO.UK

UK FACILITIES

Head Quarters

Wakefield

Manufacturing Sites

Rhyl

Bridgend

Newton Abbot

Rotherham

Kingswinford

Service

Wakefield

Rotherham

Washington

Stirling

Hinckley

Winchester



1. BEDS

Harvest Healthcare manufacture an extensive range of profiling beds designed to provide support to users. Electronically operated, our exclusive range of profiling beds offers both patient and carer ease of movement and comfort. The profiling platform has an adjustable knee break and head section, and the entire bed frame is height adjustable. Safety and durability are key aspects of our design ethos – each bed has something different to offer.

In this section, you will find the following:

Woburn Profiling Beds

Woburn Bed Accessories

Elita Profiling Beds

Elita Bed Options & Accessories

Bumpers

We offer simple-to-use bedrail height measurement tools so that you can quickly and easily check if you are compliant with Side Rail Regulations 60601/2/52.

The regulations state that the top edge of the side rail must be more than 220mm above the non-compressed mattress, and the gap between bedrails must be smaller than 120mm.

If you would like to be sent copies of the rail height measuring guide (**Product Code: RAILGUIDE**), please get in touch.



WOBURN PROFILING BEDS



Harvest Healthcare manufactures a wide range of profiling beds designed to support various service users. The exclusive range of Woburn beds and the Elita range offers ease of movement to service users and carer, providing a higher quality of life. Safety, durability and variety are key aspects in the design ethos - each bed has something different to offer.

The Woburn and Elita beds are built to comply with Side Rail Regulations. This allows rails to be used on beds without compromising the user's safety. Identifying the service user's needs before choosing a bed is of great importance. Harvest Healthcare's knowledgeable team can provide you with enough information to make such a decision.

A nationwide team of engineers are on hand to install, provide training and service profiling beds. At Harvest Healthcare, we provide a cost-effective, quality service with an honest approach – preferring to repair rather than replace wherever possible.

Our compliance checks ensure that all equipment serviced by Harvest Healthcare is reliable and efficient, enabling staff to effectively carry out their role. The health and safety of service users and staff are important to us. With ongoing support through regular training sessions and equipment audits, we will ensure that the quality of patient care increases and that professional standards are maintained.

WOBURN BED RANGE

	Max. Height (mm)	Min. Height (mm)	Safe Working Load (kg/stone)	Max. Patient Weight (kg/stone)	Overall Length (mm)	Overall Width (mm)	Max. Mattress Thickness With Rails (mm)	Warranty (Years)	200mm Extension Available	In-Built Extension (Optional)	Autoregression	Trendelenburg
Woburn	795	365	220/34	185/29	2135	1025	205	5	✓	✓	✓	✓
Woburn Low	650	220	220/34	185/29	2135	1025	205	5	✓	✓	✓	✓
Woburn Community	800	380	220/34	185/29	2115	1015	205	5	✓	✓	✓	✓
Woburn Community Low	640	220	220/34	185/29	2115	1015	205	5	✓	✓	✓	✓
Woburn Community 1200	815	385	193/30	158/25	2120	1320	205	5	✓	⊘	✓	✓
Woburn Ultra-Low	640	67	185/29	175/27	2130	900	205	5	✓	⊘	✓	✓
Woburn Ultimate 1200	690	275	381/60	300/47	2195	1340	260	5	✓	⊘	✓	✓
Woburn Ultimate 1400	690	275	381/60	300/47	2195	1540	260	5	✓	⊘	✓	✓

WOBURN COMMUNITY BED



harvesthealthcare
a prismhealthcare company

4-section profiling bed designed to fit within the community markets, the Woburn Community bed is built with the same quality across the range - at a more cost-effective price.

Vinyl-coated, the bed aids with cleaning and infection control. It is also suited for multiple dismantles across the community, part of the more robust design.

Part numbers and bed information labels are provided on each bed for ease of servicing and repair.

KEY FEATURES & BENEFITS

- Low voltage power supply (no mains voltage on the bed chassis to reduce the risk of electric shock)
- Electric backrest and knee break with mechanical lower leg support
- Locking handset
- Integral 115 mm side rails (will take up to 8" mattress) (optional)
- Inbuilt emergency battery backup
- Extendable by 200mm
- Autoregression (optional)
- Quick release actuators
- Trendelenburg as standard
- Replaceable PCB
- Replaceable actuator pistons
- Easy to install
- Padded headboards are available on request

5 year warranty



185kg/29st
max user weight



177 mm
Autoregression

Optional



0-70°
Backrest



0-30°
Footrest



380-800mm
Height
Adjustment



Trendelenburg
Function

Technical Information

Mattress Platform Dimensions	2000(L)x900(W)mm
Adjustable Height	380-800mm
Safe Working Load (SWL)	220kg/34 Stone

Product Information

Product Code	Product Description
HLBC791.02.TVC	Woburn Community Bed
HLBC791.02.TVC.SR	Woburn Community Bed with Side Rails

Optional Extras

- Length Extension: [HLDWC123](#) (Includes Base & Side Rails)
- Integral length extension is also available
- Grab Handle: [HLB685](#)
- Mattress Extension: [HFIM2016](#)
- Standard Length Rails: [HLDWC110](#)

If not purchased with the bed you may also need:

- Side Rail Fingers x 4: [HLDWC112](#)
- End Caps x 8: [HLDWC001](#)
- Bottom Stops x 4: [HLDWC122](#)
- Handset Clip: [HLDW008](#)
- Reusable Cable Retainer: [HLB603](#)

If bumpers are required please see pages (27-33)

WOBURN COMMUNITY LOW BED



harvesthealthcare
a prismhealthcare company

In addition to the Woburn Community, the Woburn Community Low profiling bed features a lower entry and exit height. Ideal for many community environments, the bed will lower to 220mm from ground level, allowing for easy access to service users.

Vinyl-coated, the bed aids with cleaning and infection control. The handset is lockable to prevent tampering by those other than carers.

Part numbers and bed information labels are provided on each bed for ease of servicing and repair.

KEY FEATURES & BENEFITS

- Low voltage power supply (no mains voltage on the bed chassis to reduce the risk of electric shock)
- Electric backrest and knee break with mechanical lower leg support
- Locking handset
- Integral 115 mm side rails (will take up to 8" mattress) (optional)
- Variable height (220 - 640mm)
- Inbuilt emergency battery backup
- Extendable by 200mm
- Trendelenburg as standard
- Quick release actuators
- Replaceable PCB
- Replaceable actuator pistons
- Easy to install
- Padded headboards are available on request

5 year warranty

185kg/29st
max user weight



177 mm
Autoregression



0-70°
Backrest



0-30°
Footrest



220-640mm
Height
Adjustment



Trendelenburg
Function

Optional

Technical Information

Mattress Platform Dimensions	2000(L)x900(W)mm
Adjustable Height	220-640mm
Safe Working Load (SWL)	220kg/34 Stone

Product Information

Product Code	Product Description
HLBC791L.TVC	Woburn Community Low Bed
HLBC791L.TVC.SR	Woburn Community Low Bed with Side Rails

Optional Extras

- Length Extension: [HLDWC123](#) (Includes Base & Side Rails)
- Integral length extension is also available
- Grab Handle: [HLB685](#)
- Mattress Extension: [HFIM2016](#)
- Standard Length Rails: [HLDWC110](#)

If not purchased with the bed you may also need:

- Side Rail Fingers x 4: [HLDWC112](#)
- End Caps x 8: [HLDWC001](#)
- Bottom Stops x 4: [HLDWC122](#)
- Handset Clip: [HLDW008](#)
- Reusable Cable Retainer: [HLB603](#)

If bumpers are required please see pages (27-33)

WOBURN BED



harvesthealthcare
a prismhealthcare company

The quality features and reliability of the Woburn profiling bed provide outstanding comfort and ease of care for both occupant and carer.

The robust wooden side rails are collapsible below mattress level and extend higher to allow a safe mattress depth of 205mm, giving scope for improved pressure relief and comfort.

Backrest, knee break and platform height can all be adjusted at the touch of a button.

Part numbers and bed information labels are provided on each bed for ease of servicing and repair.

KEY FEATURES & BENEFITS

- Low voltage power supply (no mains voltage on the bed chassis to reduce the risk of electric shock)
- Electric backrest and knee break with mechanical lower leg support
- Locking handset
- Integral 115 mm side rails (will take up to 8" mattress) (Included)
- Inbuilt emergency battery backup
- Autoregression (optional)
- Trendelenburg (optional)
- Wraparound wooden head and footboards
- Quick release actuators
- Replaceable PCB
- Replaceable actuator pistons
- Easy to install
- Padded headboards are available on request

5 year warranty



185kg/29st
max user weight



177 mm
Autoregression
Optional



0-70°
Backrest



0-30°
Footrest



365-795mm
Height
Adjustment



Trendelenburg
Function
Optional

Technical Information

Mattress Platform Dimensions	2000(L)x900(W)mm
Adjustable Height	365-795mm
Safe Working Load (SWL)	220kg/34 Stone

Product Information

Product Code	Product Description
HLB791.03.SR	Woburn Bed with Side Rails

Optional Extras

- Length Extension: [HLDWC123](#) (Includes Base & Side Rails)
- Integral length extension is also available
- Grab Handle: [HLB685](#)
- Mattress Extension: [HFIM2016](#)
- Standard Length Rails: [HLDWC110](#)

If not purchased with the bed you may also need:

- Side Rail Fingers x 4: [HLDWC112](#)
- End Caps x 8: [HLDWC001](#)
- Bottom Stops x 4: [HLDWC122.02](#)
- Handset Clip: [HLDW008](#)
- Reusable Cable Retainer: [HLB603](#)

If bumpers are required please see pages (27-33)

WOBURN LOW BED



harvesthealthcare
a prismhealthcare company

This dependable 4-section profiling bed features a high-quality control system, a reduced minimum platform height and a higher load capacity. Lowering the platform to only 220mm from floor level significantly reduces the risk of injury for those with a tendency to roll out of bed.

Part numbers and bed information labels are provided on each bed for ease of servicing and repair.

KEY FEATURES & BENEFITS

- Low voltage power supply (no mains voltage on the bed chassis to reduce the risk of electric shock)
- Electric backrest and knee break with mechanical lower leg support
- Locking handset
- Integral 115 mm side rails (will take up to 8" mattress) (optional)
- Inbuilt emergency battery backup
- Autoregression (optional)
- Trendelenburg (optional)
- Wraparound wooden head and footboards
- Quick release actuators
- Replaceable PCB
- Replaceable actuator pistons
- Easy to install
- Padded headboards are available on request

5 year warranty



185kg/29st
max user weight



177 mm
Autoregression

Optional



0-70°
Backrest



0-30°
Footrest



220-650mm
Height
Adjustment



Trendelenburg
Function

Optional

Technical Information

Mattress Platform Dimensions	2000(L)x900(W)mm
Adjustable Height	220-650mm
Safe Working Load (SWL)	220kg/34st

Product Information

Product Code	Product Description
HLB797.03	Woburn Low Bed
HLB797.03.SR	Woburn Low Bed with Side Rails

Optional Extras

- Length Extension: [HLDWC123](#) (Includes Base & Side Rails)
- Integral length extension is also available
- Grab Handle: [HLB685](#)
- Mattress Extension: [HFIM2016](#)
- Standard Length Rails: [HLDWC110](#)

If not purchased with the bed you may also need:

- Side Rail Fingers x 4: [HLDWC112](#)
- End Caps x 8: [HLDWC001](#)
- Bottom Stops x4: [HLDWC122.02](#)
- Handset Clip: [HLDW008](#)
- Reusable Cable Retainer: [HLB603](#)

If bumpers are required please see pages (27-33)

WOBURN ULTRA LOW BED



harvesthealthcare
a prismhealthcare company

The Woburn Ultra Low profiling bed is a unique system which allows the platform to be lowered to as little as 67mm from ground level.

Intended for use without side rails, the service user can safely roll onto a crash mat should they be inclined to roll whilst in bed.

Built with the Trendelenburg function as standard, service users can raise themselves to an almost standing or seated position, allowing residents to be more comfortable in bed.

Using the lockable handset, the setting of height, backrest or knee break is simple. Part numbers and bed information labels are provided on each bed for ease of servicing and repair.

KEY FEATURES & BENEFITS

- Low voltage power supply (no mains voltage on the bed chassis to reduce the risk of electric shock)
- Electric backrest and knee break with mechanical lower leg support
- Locking handset
- In-built emergency battery backup
- In-built autoregression
- Trendelenburg as standard
- Available with an enclosed headboard and footboard
- Wooden head and footboards
- Easy Cleaning - complies with MHRA guidelines
- Quick release actuators
- Replaceable PCB
- Replaceable actuator pistons
- Padded headboards are available on request

5 year warranty



175kg/27st
max user weight



177 mm
Autoregression



0-70°
Backrest



0-30°
Footrest



67-640mm
Height
Adjustment



Trendelenburg
Function

Technical Information

Mattress Platform Dimensions	2000(L)x900(W)mm
Adjustable Height	67-640mm
Safe Working Load (SWL)	185kg/29st

Product Information

Product Code	Product Description
HLB799.03AR	Woburn Ultra Low Bed

Optional Extras

- Length Extension Metal Base: [HLDWUL113.02](#)
- Grab Handle: [HLDWUL685](#)
- Mattress Extension: [HFIM2016](#)
- Mesh Side Rails for Woburn Ultra Low: [HLDWUL110](#)
- Handset Clip: [HLDW008](#)
- Reusable Cable Retainer: [HLB603](#)

If fall mats are required see page 61

WOBURN ULTRA LOW 800 BED



harvesthealthcare
a prismhealthcare company

A fully functioning four-section Ultra-Low profiling bed. The platform can be lowered to 90mm off the floor for patient safety and raised to 800mm to make it easier for the carer to provide patient care. Using the lockable handset, automatically setting height, backrest, or knee brake is simple. The Woburn Ultra-Low 800 has a Trendelenburg function as standard. 275-690mm

Optional bed levels, lighting and accessories are available.

KEY FEATURES & BENEFITS

- Low voltage power supply (no mains voltage on the bed chassis to reduce the risk of electric shock)
- Electric backrest and knee break with mechanical lower leg support
- Locking handset
- Emergency battery backup
- In-built autoregression
- Trendelenburg as standard
- Wooden head and footboards
- Easy Cleaning - complies with MHRA guidelines
- Compatible with environmental control system
- Padded headboards are available on request

5 year warranty

175kg/27st
max user weight



177 mm
Autoregression



0-70°
Backrest



0-30°
Footrest



90-800mm
Height
Adjustment



Trendelenburg
Function

Technical Information

Mattress Platform Dimensions	2000(L)x900(W)mm
Adjustable Height	90-800mm
Safe Working Load (SWL)	185kg/29st

Product Information

Product Code	Product Description
HLB800.01AR	Woburn Ultra Low 800 Bed

Optional Extras

- Length Extension Metal Base: [HLDWUL113.03](#)
- Grab Handle: [HLDWUL685](#)
- Mattress Extension:
- Mesh Side Rails for Woburn Ultra Low 800: [HLDWUL8110](#)
- Reusable Cable Retainer: [HLB603](#)

If fall mats are required see page 61

WOBURN COMMUNITY 1200 BED



harvesthealthcare
a prismhealthcare company

The Woburn Community 1200 is Harvest's first wide profiling bed, built to the same high quality as other beds in the range. Although not a bariatric bed, it has a safe working load of 30 stone.

The generous width allows patients to move freely. The lockable handset allows for quick height adjustments, backrest and knee break, and the attractive vinyl-clad head and footboards facilitate infection control. This bed is for one-person use only and is not for plus-size patients.

The bed is designed for easy cleaning to aid infection control. Part numbers and bed information labels are provided on each bed for ease of servicing and repair.

KEY FEATURES & BENEFITS

- Low voltage power supply (no mains voltage on the bed chassis to reduce the risk of electric shock)
- Electric backrest and knee break with mechanical lower leg support
- Locking handset
- Integral 115 mm side rails (will take up to 8" mattress) (Included)
- Inbuilt emergency battery backup
- In-built autoregression
- Trendelenburg as standard
- Quick release actuators
- Replaceable PCB
- Replaceable actuator pistons
- Easy to install
- Also available in vinyl-coated wooden head and footboards
- Padded headboards are available on request

5 year warranty



158kg/25st
max user weight



177 mm
Autoregression



0-70°
Backrest



0-30°
Footrest



385-815mm
Height
Adjustment



Trendelenburg
Function

Technical Information

Mattress Platform Dimensions	2000(L)x1200(W)mm
Adjustable Height	385-815mm
Safe Working Load (SWL)	193kg/30st

Product Information

Product Code	Product Description
HLBC791.12AR.TVC	Woburn Community 1200
HLBC791.12AR.TVC.SR	Woburn Community 1200 with Side Rails

Optional Extras

- Length Extension Metal Base: [ENWIDE002](#)
 - Length Extended Rails: [HLDWC111](#)
 - Integral length extension is also available
 - Grab Handle: [HLB685](#)
 - Mattress Extension: [HFIM2016](#)
 - Standard Length Rails: [HLDWC110](#)
- If not purchased with the bed you may also need:
- Side Rail Fingers x 4: [HLDWC112](#)
 - End Caps x 8: [HLDWC001](#)
 - Bottom Stops x 4: [HLDWC122](#)
 - Handset Clip: [HLDW008](#)
 - Reusable Cable Retainer: [HLB603](#)

If bumpers are required please see pages (27-33)

WOBURN ULTIMATE BED



harvesthealthcare
a prismhealthcare company

The Woburn Ultimate Profiling Bed is the highest capacity bed within the Woburn range. Featuring triple aluminium side rails and under-bed strengthening, the Ultimate excels in patient support and ease of infection control.

Available in 1200mm and 1400mm wide, with a 60stone weight capacity, this bed can support most bariatric patients. Comfort adjustments are easily made due to the powerful lifting components and the high-quality electronic control system.

Part numbers and bed information labels are provided on each bed for ease of servicing and repair.

KEY FEATURES & BENEFITS

- Low voltage power supply (no mains voltage on the bed chassis to reduce the risk of electric shock)
- Electric backrest and knee break with mechanical lower leg support
- Locking handset
- Aluminium side rails
- Wooden head and footboards
- Inbuilt emergency battery backup
- In-built autoregression
- Trendelenburg as standard
- In-built stability system
- Quick release actuators
- Replaceable PCB
- Replaceable actuator pistons
- Padded headboards are available on request

5 year warranty



300kg/47st
max user weight



177 mm
Autoregression



0-70°
Backrest



0-30°
Footrest



275-690mm
Height
Adjustment



Trendelenburg
Function

Technical Information

	HLB798.12	HLB798.14
Mattress Platform Dimensions	2000(L)x1200(W)mm	2000(L)x1400(W)mm
Adjustable Height	275-690mm	275-690mm
Safe Working Load (SWL)	381kg/60st	381kg/60st

Product Information

Product Code	Product Description
HLB798.12	Woburn Ultimate 1200 with Side Rails
HLB798.14	Woburn Ultimate 1400 with Side Rails

Optional Extras

- Length Extension Kit for 1200 Wide Bed: [HLDWC123.12](#) (includes metal base & rails extensions)
- Mattress Extension 1200 Wide: [HFIM2016.12](#)
- Length Extension Kit for 1400 Wide Bed: [HLDWC123.14](#) (includes metal base & rails extensions)
- Mattress Extension 1400 Wide: [HFIM2016.14](#)
- Grab Handle: [HLB686](#)
- Handset Holder:
- Reusable Cable Retainer: [HLB603](#)

If bumpers are required please see pages (27-33)

ELITA PROFILING BEDS



ELITA BED RANGE

	Max. Height (mm)	Min. Height (mm)	Safe Working Load (kg/stone)	Max. Patient Weight (kg/stone)	Overall Length (mm)	Overall Width (mm)	Max. Mattress Thickness With Rails (mm)	Alternative Finish Available	Warranty (Years)	200mm Extension Available	In-Built Extension (Optional)	Autoregression	Trendelenburg
Elita	800	400	175/27	135/21	2150	1020	150	✓	5	✓	∅	✓	✓
Elita Low	630	230	175/27	135/21	2150	1020	150	✓	5	✓	∅	✓	✓
Elita Select	800	390	175/27	135/21	2065	1020	150	✓	5	✓	∅	∅	∅
Elita Select Low	720	290	175/27	135/21	2070	1060	150	✓	5	✓	∅	∅	∅
Elita Premium	810	310	220/34	180/28	2060	1070	150	✓	5	✓	✓	✓	✓
Elita Comfort	800	390	175/27	135/21	2060	1110	150	✓	5	✓	∅	∅	∅

ELITA STANDARD BED



harvesthealthcare
a prismhealthcare company

The Elita is a premium profiling bed providing exceptional care and a soft, home-from-home look.

Four profiling sections allow for optimum comfort and clinical support. They can be independently adjusted by users using the ergonomic, lockable handset.

Fully customisable, the Elita comes with multiple colour options, wraparound head and footboards, and optional Trendelenburg and autoregression.

KEY FEATURES & BENEFITS

- Lockable handset
- Electric backrest and knee break with mechanical lower leg support
- Autoregression (optional)
- Trendelenburg (optional)
- Stylish wooden side rails
- Wraparound head and footboards
- 4 braked castors
- Available in 8 colours
- Full upholstered headboards are available on request

5 year warranty



135kg/21st
max user weight



Nabucco



Light Beech



Maple



Light Oak



Beech



Acacia



Cherry



Walnut

Product Information

Product Code	Mattress Platform Dimensions	Adjustable Height	Safe Working Load (SWL)
HLB558	2000(L)x900(W)mm	400-800mm	175kg/27st

ELITA LOW BED



harvesthealthcare
a prismhealthcare company

The Elita Low is a premium profiling bed which lowers to just 230mm from the floor. Ideal for patients at risk of bed falls, the Elita Low provides exceptional care whilst maintaining a warm aesthetic.

Four profiling sections allow for optimum comfort and clinical support. They can be independently adjusted by users using the ergonomic, lockable handset.

Fully customisable, the Elita Low comes with multiple colour options, wraparound head and footboards, and optional Trendelenburg and autoregression.

KEY FEATURES & BENEFITS

- Lockable handset
- Electric backrest and knee break with mechanical lower leg support
- Autoregression (optional)
- Trendelenburg (optional)
- Stylish wooden side rails
- Wraparound head and footboards
- Available in 8 colours
- 4 braked castors
- Full upholstered headboards are available on request



5 year warranty



135kg/21st
max user weight



Nabucco



Light Beech



Maple



Light Oak



Beech



Acacia



Cherry



Walnut

Product Information

Product Code	Mattress Platform Dimensions	Adjustable Height	Safe Working Load (SWL)
HLB559	2000(L)x900(W)mm	230-630mm	175kg/27st

ELITA SELECT BED



harvesthealthcare
a prismhealthcare company

The Elita Select is a premium scissor action profiling bed which complies with the highest standards. The scissor setup means the Elita Select can be fitted with a low footboard making it one of the most attractive beds in the Elita range.

The four profiling sections provide optimum comfort and clinical support. They can be independently adjusted by users using the ergonomic, lockable handset.

Fully customisable, the Elita Select comes with multiple colours, side rail set-ups and headboard and footboard options.

KEY FEATURES & BENEFITS

- Lockable handset
- Electric backrest and knee break with mechanical lower leg support
- Split side rails (optional)
- No side rails (optional)
- Low footboard on request
- Stylish wooden head and footboards and side rails
- Wraparound head and footboards
- 4 braked castors
- Available in 8 colours
- Available in 900mm, 1050mm and 1200mm wide
- Full upholstered headboards are available on request



5 year warranty



135kg/21st
max user weight



Nabucco



Light Beech



Maple



Light Oak



Beech



Acacia



Cherry



Walnut



Available headboard and footboard options

Product Information

Product Code	Mattress Platform Dimensions	Adjustable Height	Safe Working Load (SWL)
HLB561	2000(L)x900(W)mm	390-800mm	175kg/27st

ELITA SELECT LOW BED



harvesthealthcare
a prismhealthcare company

The Elita Select Low is a premium scissor action profiling bed that complies with the highest standards and lowers to 290mm from the floor. Ideal for patients at risk of bed falls, the Elita Select Low provides exceptional care whilst maintaining a warm aesthetic.

The scissor setup means the Elita Select Low can be fitted with a low footboard making it one of the most attractive beds in the Elita range while maintaining user safety. The four profiling sections provide optimum comfort and clinical support. They can be independently adjusted by users using the ergonomic, lockable handset.

Fully customisable, the Elita Select Low comes with multiple colours, side rail setups and headboard and footboard options.

KEY FEATURES & BENEFITS

- Lockable handset
- Electric backrest and knee break with mechanical lower leg support
- Split side rails (optional)
- Low footboard on request
- Stylish wooden head and footboards and side rails
- Wraparound head and footboards
- 4 braked castors
- Available in 8 colours
- Full upholstered headboards are available on request



5 year warranty



135kg/21st
max user weight



Nabucco



Light Beech



Maple



Light Oak



Beech



Acacia



Cherry



Walnut



Available headboard and footboard options

Product Information

Product Code	Mattress Platform Dimensions	Adjustable Height	Safe Working Load (SWL)
HLB560	2000(L)x900(W)mm	290-720mm	175kg/27st

ELITA COMFORT BED



harvesthealthcare
a prismhealthcare company

The Elita Comfort profiling bed has a timeless design and complies with the highest standards.

The four profiling sections provide optimum comfort and clinical support. They can be independently adjusted by users using the ergonomic, lockable handset.

Highly customisable, the Elita Comfort comes in multiple colours and widths.

KEY FEATURES & BENEFITS

- Lockable handset
- Electric backrest and knee break with mechanical lower leg support
- No side rails as standard
- Low footboard as standard
- Wraparound head and footboards
- 4 braked castors
- Available in 8 colours
- Available in 900mm, 1050mm and 1200mm wide
- 4 braked castors
- Full upholstered headboards are available on request

5 year warranty



135kg/21st
max user weight



Nabucco



Light Beech



Maple



Light Oak



Beech



Acacia



Cherry



Walnut

Product Information

Product Code	Mattress Platform Dimensions	Adjustable Height	Safe Working Load (SWL)
HLB562	2000(L)x900(W)mm	390-800mm	175kg/27st

ELITA PREMIUM BED



harvesthealthcare
a prismhealthcare company

The Elita Premium is a top-of-the-range profiling bed. Combining a warm, cosy look with clinical excellence, the Elita Premium gives users and carers an exceptional experience.

The height range of the Elita Premium gives the option to transition from a standard height bed to a low one, providing flexibility to meet the user's needs. The quality castors provide smooth manoeuvrability. The high safe working load means the Elita Premium suits most users. The four profiling sections offer optimum comfort and clinical support. They can be independently adjusted by users using the ergonomic, lockable handset. The Elita Premium also boasts Trendelenburg and autoregression as standard.

Fully customisable, the Elita Premium comes in multiple colours and with different side rail setups and headboard and footboard options.

KEY FEATURES & BENEFITS

- Lockable handset
- Electric backrest and knee break with mechanical lower leg support
- Autoregression
- Trendelenburg as standard
- The in-built extension (optional)
- Split side rails (optional)
- Low footboard on request
- Stylish wooden head and footboards and side rails (optional)
- Wraparound head and footboards
- 4 braked castors
- Available in 8 colours
- Full upholstered headboards are available on request

5 year warranty



180kg/28st
max user weight



Nabucco



Light Beech



Maple



Light Oak



Beech



Acacia



Cherry



Walnut



Available headboard and footboard options

Product Information

Product Code	Mattress Platform Dimensions	Adjustable Height	Safe Working Load (SWL)
HLB563	2000(L)x900(W)mm	310-810mm	220kg/34st

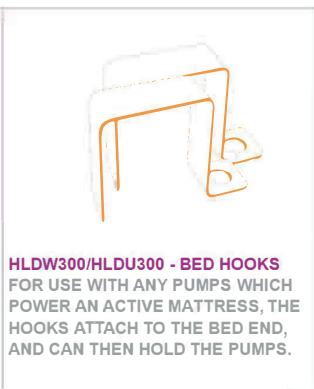
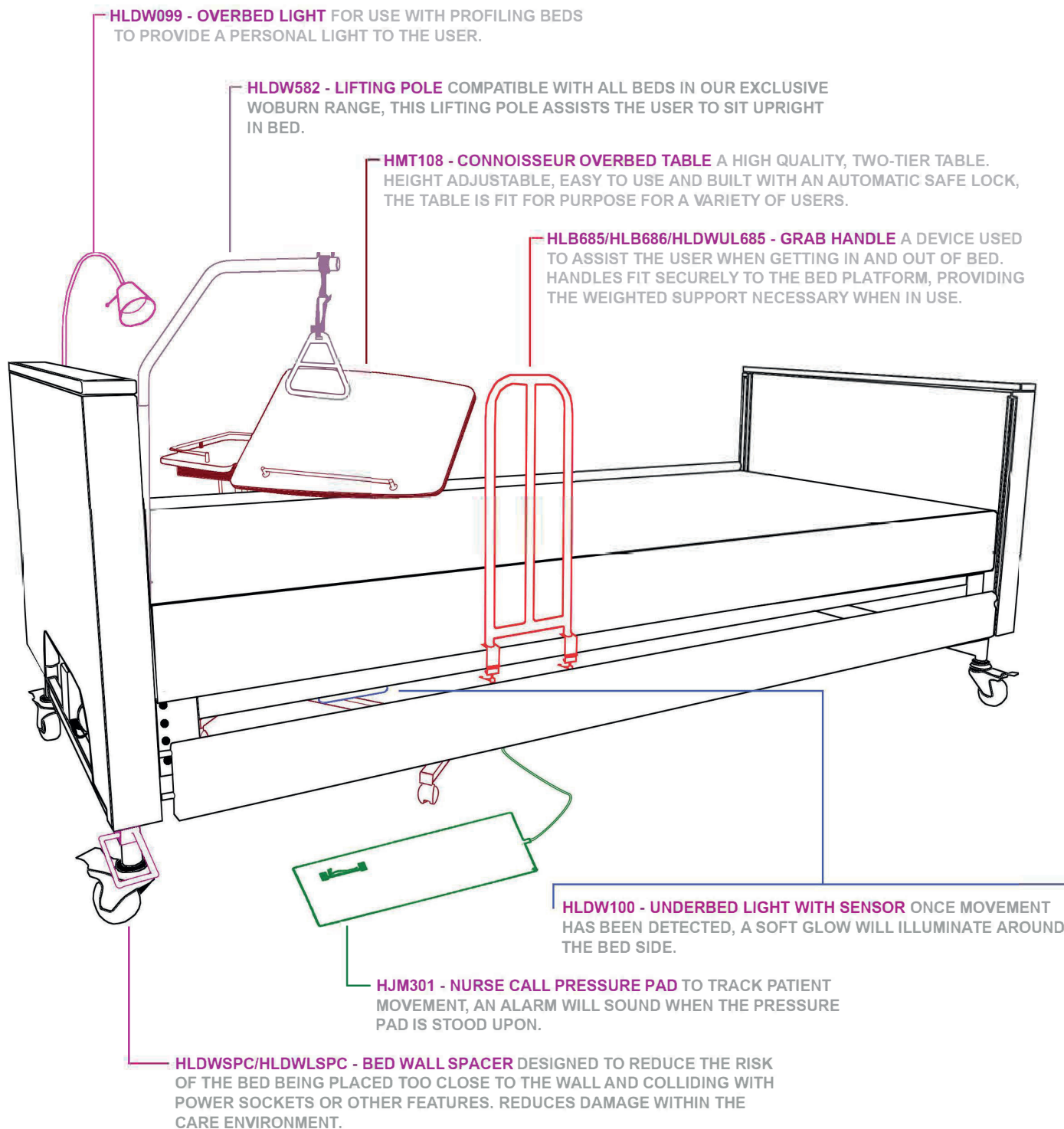



harvesthealthcare
a prismhealthcare company

IN-BUILT EXTENSION

Harvest has introduced the In-Built Platform Extension to remove the need for removable platforms.

These add an additional 200mm to the Woburn beds only when needed. The modern beds are now more adaptable for a broader range of residents.



AUTOREGRESSION

AutoRegression Backrests provide patients with a more comfortable position.

The mechanisms steadily raise or lower the patient whilst controlling posture - this reduces the 'push-down' effect on the body, keeping the resident more central in the bed and removing shear and friction forces upon the body.

HOW CAN AUTOREGRESSION HELP PREVENT PRESSURE INJURY?

A standard backrest pushes the user down the bed as it raises, creating shear forces and increasing the risk of tissue damage.

Autoregression backrests move slowly backwards at the sacral area as they raise. This allows the bed to move fully around the user rather than the user being moved to accommodate the bed.

This means the sacral area and heels do not move as the bed profiles. This removes the risk of shear and friction, which protects against tissue damage, prevents the need for repositioning and maintains user comfort.

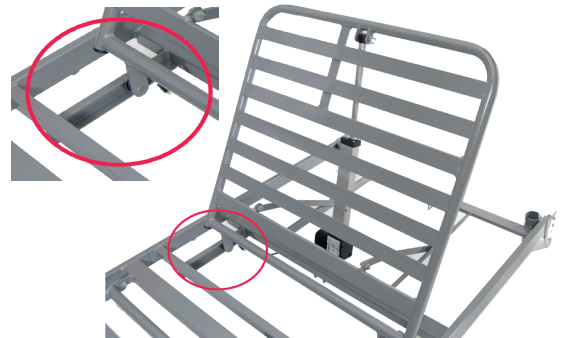

TRENDELENBURG FUNCTION

The Trendelenburg Function is available across the Woburn Bed Range. This function enables the carer to raise the foot end of the profiling bed higher than the head end, which is beneficial for use with respiratory patients. Anti-Trendelenburg enables the head end to be elevated higher than the feet, improving posture, allowing patients to feel as though they are standing or are seated whilst in bed and can increase blood flow.





harvesthealthcare
a prismhealthcare company

GRAB HANDLE FOR WOBURN BED

The Grab Handles assist the patient in sitting up and getting in and out of bed. They fit securely to the bed frame - no additional fixings are required. They have a durable epoxy coating and can be used without removing the side rails. They can be used with Woburn, Woburn Ultimate and Woburn Ultra-Low beds.

Product Information

Product Code	Description	Safe Working Load (SWL)
HLB685	Grab Handle for Woburn Standard	60kg/9st
HLB686	Grab Handle for Woburn Ultimate	60kg/9st
HLDWUL685	Grab Handle for Woburn Ultra Low	60kg/9st

Dimensions: 240mm(W)x610mm(H) from platform



STANDARD LIFTING POLE

The Lifting Pole is made to be compatible with the Woburn Standard bed. It slots securely into sockets provided in the bed frame and has a durable powder-coated finish. It assists the occupant in sitting up in bed by holding onto the triangular handle.

Product Information

Product Code	Description	Safe Working Load (SWL)
HLDW582	Standard Lifting Pole with Handle	80kg/12st
HLB680	Handle	N/A



LIFTING POLE - ULTIMATE

The Ultimate 1200 Lifting Pole is made to be compatible with the Woburn Ultimate 1200 bed. It slots securely into sockets provided in the bed frame and has a durable powder-coated finish. It assists the occupant in sitting up in bed by holding onto the triangular handle.

Product Information

Product Code	Description	Safe Working Load (SWL)
HLDU582	Ultimate 1200 Lifting Pole with Handle	80kg/12st
HLDU582.14	Ultimate 1400 Lifting Pole with Handle	80kg/12st
HLB680	Handle	N/A





harvesthealthcare[®]
a prismhealthcare company

OVER-BED READING LIGHT

The Over-Bed Light is compatible with the full Woburn bed range. It is safe and simply connects to the low-voltage power supply of the bed. It comes complete with an adjustable switch position and manoeuvrable head section. The light provides a valuable touch of home comfort, providing convenient directed lighting.



Product Information

Product Code	Description
HLDW099	Overbed Light

UNDER-BED LIGHT WITH MOVEMENT SENSOR

The Under-Bed Light uses an energy-efficient LED light, compatible with the full Woburn bed range. It simply connects to the low-voltage bed supply. It is safe and maintains a low temperature. The built-in sensor detects movement when the user leaves the bed and illuminates underneath and around the bed, helping to prevent trips and falls.



Product Information

Product Code	Description
HLDW100	Under Bed Light with Sensor for Woburn Beds

BED WALL SPACER

These spacers are designed to reduce the risk of the bed being placed too close to the wall and colliding with power sockets or other features. This can be costly to fix and often requires an emergency callout; the Bed Wall Spacer can eliminate these costs.

It increases safety by reducing the risk of electric shock due to socket damage. The Bed Wall Spacer also protects the bed chassis from damage if being operated against window sills/skirting boards or other features, which can be expensive to fix.

Product Information

Product Code	Description
HLDWLSPC	Bed Wall Spacer (Pair) for the Woburn & Woburn Low Beds





harvesthealthcare
a prismhealthcare company

BED LENGTH EXTENSION

The Bed Length Extension Platform can extend your profiling bed by an additional 200mm. Some users are uncomfortable in a typical 2000mm long Profiling Bed, which can cause entrapment issues.

Product Information

Product Code	Dimensions
HLDWC110	Full Length Wooden Side Rails for Woburn Beds (set of 4)
HLDWC111	Extended Wooden Side Rails (set of 4)
HLDW113	Bed Length Extension Section 900mm(W)x200mm(L)
HLDW123	Woburn Side Rails Length Extension Pack 900mm Wide Bed
HLDWC123	Side Rail Length Extension Pack 115mm Height Rails
HLDU123.12	Ultimate 1200 Bed Length Extension Kit
HLDU123.14	Ultimate 1400 Bed Length Extension Kit



MESH SIDE RAILS FOR WOBURN ULTRA LOW AND ULTRA LOW 800

The Mesh Side Rail System is intended to provide security to the occupant of the bed whilst the bed is raised to the correct height for giving care. This reduces the risk of a fall from the bed or potential entrapment from a side rail system. It can be used with the enclosed head and footboards with some adjustments.

Product Information

Product Code	Description
HLDWUL110	Full Length Mesh Side Rails for Woburn Ultra Low Bed
HLDWUL8110	Full Length Mesh Side Rails for Woburn Ultra Low 800 Bed



MATTRESS LENGTH EXTENSION

The Static Mattress Length Extensions have been designed for use with our Static Mattress range.

Ideal for use with existing mattresses, the piece will add a further 200mm to the length of the mattress and close any gaps between the mattress and bed frame. It is available in both 900mm and 1200mm widths.

Once in place, the kit provides pressure relief around the heels and zonal areas.

Product Information

Product Code	Dimensions
HFIM2013	200(L) x 900(W) x 130(H)mm
HFIM2016	200(L) x 900(W) x 160(H)mm
HFIM2016.12	200(L) x 1200(W) x 160(H)mm
HFIM2020	200(L) x 900(W) x 200(H)mm

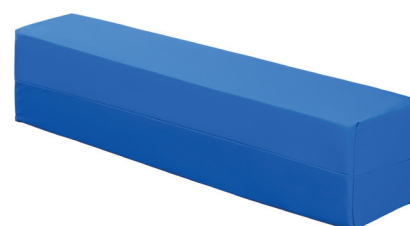

CONNOISSEUR OVER BED TABLE



harvesthealthcare
a prismhealthcare company

The Connoisseur Over-bed Table is a high-quality, two-tier table. Height adjustable, easy to use and built with an automatic safety lock, the table is fit for purpose for a variety of users.

2 vinyl-wrapped trays allow for more usability and provide more space. Available in Oak, Walnut and other Elita bed finish options.

It can be used for both Woburn and Elita range profiling beds.

KEY FEATURES & BENEFITS

- Height adjustable, hand-operated steel column
- Easy-to-use height control handle
- Automatic safe lock
- Available in oak, walnut and more
- U-shaped base
- 2 vinyl-wrapped trays



Nabucco



Light Beech



Maple



Light Oak



Beech

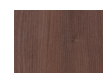

Acacia

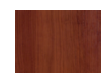

Cherry

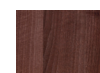

Walnut

Product Information

Product Code	Dimensions	Adjustable Height	Castors Size
HMT107W (Walnut) HMT107OK (Oak)	440mm x 890mm (Overall Surface Area) 830mm x 410mm (U-shaped base) 40mm x 40mm (Tube Steel)	760mm-1150mm	4x50mm

STANDARD BUMPER ANTI-ENTRAPMENT BUMPER



STANDARD BUMPER WITH NET/MESH INSERT

The Standard Bumper with net/mesh inserts is designed to fit over side rails, providing safe protection for users in bed. The net/mesh inserts are entwined with the bumpers to improve visibility between each side rail, reducing the feeling of entrapment. The bumper fits all Woburn beds. All the bumpers come with removable and machine-washable covers for better infection control.



Product Information

Product Code	Description
HCSBUMP112	Standard Bumper with Net/Mesh Inserts for Woburn, Community & 1200 Bed (L: 2000 mm)
HCSBUMP212	Extended Bumper with net/mesh inserts for Woburn, Community & 1200 Bed (L: 2200 mm)
HCSBUMP130	Standard Bumper with Net/Mesh Inserts for Woburn Ultimate Bed (L: 2000 mm)

ANTI-ENTRAPMENT BUMPER WITH NET/MESH INSERT

The Anti-Entrapment Bumper is a 2-bar bumper with a net/mesh insert and an anti-entrapment system with a link sheet. Designed for users who move excessively in bed to prevent limbs from becoming trapped. The Anti-Entrapment Bumper fits all standard-width Woburn beds whilst also being suitable for most other manufacturers' beds with two full-length wooden side rails at each side of the bed. We also offer the Anti-Entrapment Bumper for beds with 3 bar side rails (Ultimate/Safeguard).

All the bumpers come with removable and machine-washable covers for better infection control.



Product Information

Product Code	Description
HCSAEBUMP791	Anti-Entrapment Bumper with Net/Mesh Inserts for Woburn & Community Bed
HCSAEBUMP140	Anti-Entrapment Bumper with Net/Mesh Inserts for Beds with 3 Bar Side Rails (Ultimate/Safeguard)

EXTENDED STANDARD BUMPER

EXTENDED ANTI-ENTRAPMENT BUMPER



EXTENDED LENGTH STANDARD BUMPER WITH NET/MESH INSERT

The 200mm Length Extension, suitable for the Standard Bumper with net/mesh inserts, is designed to fit over side rails, providing safe protection for users in bed. Created for use when the bed has been extended, ensuring complete protection for the user. All the bumpers come with removable and machine-washable covers for better infection control.



Product Information

Product Code	Description
HCSBUMP112 + HCSBUMP112.EX20	Extended Standard Bumper with Net/Mesh Inserts for Woburn, Community & 1200 Bed
HCSBUMP130 + HCSBUMP130.EX20	Extended Standard Bumper with Net/Mesh Inserts for Woburn Ultimate Bed

EXTENDED LENGTH ANTI-ENTRAPMENT BUMPER WITH NET/MESH INSERT

The 200mm Length Extension is suitable for the Anti-Entrapment Bumper with net/mesh inserts and anti-entrapment system with link sheet. Designed for users who move excessively in bed to prevent limbs from becoming trapped. Created for use when the bed has been extended, ensuring complete protection for the user. All the bumpers come with removable and machine-washable covers for better infection control.



Product Information

Product Code	Description
HCSAEBUMP791 + HCSAEBUMP791.EX20	Extended Anti-Entrapment Bumper with Net/Mesh Inserts for Woburn & Community Bed
HCSAEBUMP140 + HCSAEBUMP140.EX20	Extended Anti-Entrapment Bumper with Net/Mesh Inserts for Woburn Ultimate Bed

CONTACT PAD HEAD AND FOOT BUMPER



CONTACT PAD FOR ANTI-ENTRAPMENT BUMPER

Designed for use with the Harvest Anti-Entrapment Bumper, the contact pads protect users with involuntary movement from skin damage and prevent the risk of friction injury from contact with the mesh inserts. The pads can be positioned anywhere inside the bed with a Hook and Loop fastening. All the bumpers come with removable and machine-washable covers for better infection control.



Product Information

Product Code	Description
HCS140CONTP	Contact Pad for Anti-Entrapment Bumper

HEAD AND FOOTBOARD BUMPER

The Head and Footboard bumper fits all Woburn and Community Beds. Providing extra protection for the user at the head and foot end of the bed. All the bumpers come with removable and machine-washable covers for better infection control.



Product Information

Product Code	Description
HBCWOB	Head and Footboard Bumper for Woburn, Woburn Low and Woburn Community Beds
HBCCOM1.12	Head and Footboard Bumper for Woburn Community 1200 Bed
HBCULT	Head and Footboard Bumper for Woburn Ultimate Beds

SPECIALIST ANTI-ENTRAPMENT BUMPER



harvesthealthcare[®]
a prismhealthcare company

SPECIALIST ANTI-ENTRAPMENT BUMPER

Adults of small stature or juniors are at increased risk of entrapment in a standard adult bed. This innovative solution quickly transforms a Community Woburn bed, making it suitable for smaller occupants. It meets junior bed regulations when paired with a locking handset box. All the bumpers come with removable and machine-washable covers for better infection control.

Please find the installation video on our website.



Product Information

Product Code	Description
HJB002	Specialist Anti-Entrapment Bumper for Community Woburn Bed

Please click on the image below to see how to install our Specialist Anti-Entrapment Bumper.

Alternatively, please visit Harvest Healthcare's YouTube page and find the Specialist Anti-Entrapment Bumper video.

<https://tinyurl.com/Specialist-Bumper>

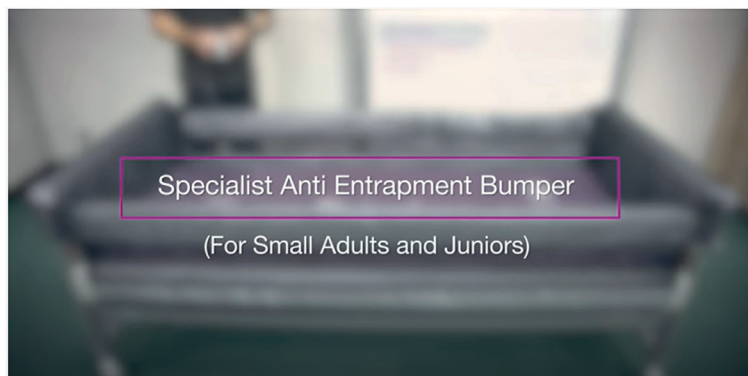

WRAPOVER BUMPER STANDARD AND HEIGHT EXTENSION



WRAPOVER BUMPER

Designed for users who are inclined to roll whilst in bed, extra protection may be necessary. The Wrapover Bumper surrounds the bedside rails, providing patients with a safe and cushioned barrier. The three-quarter length bumper wraps over the side rails and secures with Hook and Loop at the bottom, ensuring ease of use. All the bumpers come with removable and machine-washable covers for better infection control.



WRAPOVER BUMPER STANDARD & HEIGHT EXTENSION (200MM)

The 200mm height extension suitable for the Wrapover Bumper surrounds the bedside rails, providing a safe and cushioned barrier for patients. Designed for use when the height attachment side rails are placed onto the bed, ensuring complete protection for the user.

WRAPOVER BUMPER STANDARD & LENGTH EXTENSION (500MM)

The 500mm extension for the Wrapover Bumper surrounds the bedside rails, providing patients with a safe and cushioned barrier. Designed for use when the bed has been extended, ensuring complete protection for the user.



Product Information

Product Code	Description
HCSWRAP113	Harvest Wrapover Bumper Standard
HCSWRAP113 + HCSWRAP113.EX20HEIGHT	Harvest Wrapover Bumper Standard & Height Extension (200mm)
HCSWRAP113 + HCSWRAP113.EX50	Harvest Wrapover Bumper Standard & Length Extension (500mm)

UNIVERSAL SAFE ROLL BUMPER



UNIVERSAL SAFE ROLL

The Universal Safe Roll system is a state-of-the-art crash mat designed to dramatically change the landscape of fall protection and support, reducing the use of side rails. Traditional static floor mats are often a trip hazard, must be moved to accommodate moving and handling equipment, and are frequently too thin to provide proper protection from falls. This radical new design eliminates all these issues, providing safety for the resident and exceptional ease of use for carers.

The folding mat attaches to the side of the bed and Hooks and Loops up when the bed is raised for care (image 1), enabling access for carers and equipment. As the bed is lowered, the deep foam mat folds out to lie alongside the bed, as a true safety feature (image 2). Designed to fit our Woburn Ultra Low, Low and standard beds, the Universal Safe Roll is suitable for a wide range of users and is ideal for use within nursing homes and the domestic environment.

All the bumpers come with removable and machine-washable covers for better infection control.



Image 1



Image 2

Product Information

Product Code	Description
HFB003	Universal Safe Roll Bumper

Please click on the image below to see how to install our Universal Safe Roll.

Alternatively, please go to Harvest Healthcare's YouTube page and find the Universal Safe Roll video.

<https://tinyurl.com/Universal-Safe-Roll>

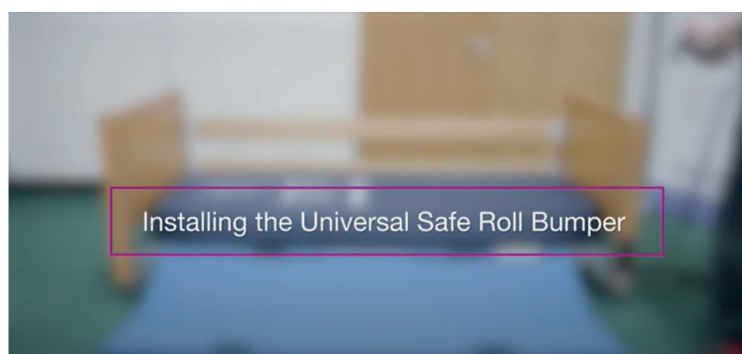

SNUG WALL BUMPER / BED SIDE PLATFORM BUMPER / SAFETY WEDGES



SNUG WALL BUMPER

The Snug Wall Bumper has been designed to fit onto our **Woburn bed range** or similar profiling beds produced by other manufacturers. Beds often need to be placed slightly away from the wall due to room fittings and fixtures, which can leave a gap. This can be an entrapment risk, and the Snug Bumper unobtrusively and comfortably fills this space. This removes the entrapment risk without requiring side rails to be fitted. The easy-to-fit bumper helps to prevent accidental contact with the wall. It is created using soft-to-the-touch material and spacer mesh to avoid the risk of suffocation and increase patient safety. All the bumpers come with removable and machine-washable covers for better infection control.

Please click on the image to see how to install the bumper.

Alternatively, please go to Harvest Healthcare's YouTube page and find the Snug Wall Bumper video.
<https://tinyurl.com/Snug-Wall>



Product Information

Product Code	Description
HWB003	Snug Wall Bumper

BED SIDE PLATFORM BUMPER

The Bed Side Platform Bumper has been designed to easily fit onto the outer edge of the bed frame to reduce the risk of injury for patients on the frame when getting in and out of bed. Created using soft-to-the-touch material, protecting the user and increasing patient safety. Suitable for use on all our Woburn beds and similar profiling beds produced by other manufacturers.

All the bumpers come with removable and machine-washable covers for better infection control.



Product Information

Product Code	Description
HWB004	Bed Side Platform Bumper

SAFETY WEDGE

The Safety Bed Wedges provide a safe, firm, sloping barrier to keep the user comfortably positioned whilst in bed. The wedges are connected to a waterproof base sheet meaning the product is easy to fit and will be secure once fitted onto the bed. All the bumpers come with removable and machine-washable covers for better infection control.



Product Information

Product Code	Description
HCS096	Safety Wedges with Double Duty Hook and Loop Base Sheet
HCS096B	Safety Wedges 900x900mm with Hook and Loop Loop

2. MATTRESSES AND CUSHIONS

Harvest Healthcare have a wide range of active and static mattresses and cushions, designed with comfort, pressure relief and weight distribution in mind to meet your needs.

Varying levels of protection are available for static mattresses; it all depends on the foam chosen and where the profile sections are cut.

To make the choice easier for active mattresses, we have created a mattress selector based on maximum user weight, mattress width and user risk. This selector can be seen below.

We also offer hybrid mattresses to allow you to step up or down the pressure-relieving abilities of the mattress.

In this section, you will find the following:

Static Mattresses

Hybrid Mattresses

Active Mattresses

Pumps

Fall Mats, Underlays and Overlays

Cushions

Active Mattress Selector

Width	900mm					1200mm	1400mm
Maximum User Weight	25 Stone 158kg	26 Stone 165kg	29 Stone 184kg	39 Stone 247kg	40 Stone 254kg	50 Stone 317kg	50 Stone 317kg
High Risk	Kensington Overlay with Harvest 1 Pump Sandringham Replacement with Harvest 1 Pump		Kensington Overlay with Harvest 2 Pump Sandringham Replacement with Harvest 2 Pump	Prime Comfort Active Replacement without pump			
Very High Risk	Hampton Replacement with Harvest 1 Pump	Duke Replacement with Harvest 2 Pump	Hampton Replacement with Harvest 2 Pump Windsor Replacement with Harvest 2 Pump Balmoral	Prime Comfort Active Replacement with pump Duke Replacement with Harvest 3	Hampton Replacement with Harvest 3 Pump Windsor Replacement with Harvest 3 Pump Balmoral	Duke Extra 2.0 Replacement with Harvest 3 Pump Hampton Extra Replacement	

COMMUNITY STATIC MATTRESS



The Community static mattress is a cost-effective comfort mattress for profiling beds. The foam is highly resilient and fire retardant. The Community mattress provides pressure distribution and can be turned to extend service life. The mattress is available with castellated foam on request.

KEY FEATURES & BENEFITS

- Cost-effective
- Highly resilient foam
- Four-way stretch, waterproof, anti-bacterial zipped cover with a crib 5 fire rating
- Shaped to allow profiling
- Two-way turn to extend the life of the mattress
- Additional sizes available upon request
- Medium risk

3 year warranty

159kg/25st
max user weight



Product Information

Product Code	Description	Mattress Dimensions	Mattress Weight
HSMCOM	Community 900mm Wide	2000(L)x900(W)x125(H)mm	8kg
HSMCOM.12	Community 1200mm Wide	2000(L)x1200(W)x125(H)mm	10kg

COMMUNITY PLUS STATIC MATTRESS



harvesthealthcare[®]
a prismhealthcare company

The Community Plus static mattress is an enhanced version of the Community mattress, with higher quality but remaining cost-effective. The thicker foam offers better pressure distribution and support whilst maintaining the same comfort level. The mattress is available with castellated foam on request.

KEY FEATURES & BENEFITS

- Cost-effective
- Highly resilient foam
- Four-way stretch, water resistant, anti-bacterial zipped cover with a crib 5 fire rating
- Shaped to allow profiling
- Two-way turn to extend the life of the mattress
- Additional sizes available upon request
- High risk

3 year warranty



190kg/30st
max user weight



LOW MED HIGH V HIGH

PRESSURE RELIEF RISK

Product Information

Product Code	Description	Mattress Dimensions	Mattress Weight
HSMCOMP	Community Plus 900mm Wide	2000(L)x900(W)x150(H)mm	8.5kg
HSMCOMP.12	Community Plus 1200mm Wide	2000(L)x1200(W)x150(H)mm	11kg

PRIME COMFORT STATIC MATTRESS



harvesthealthcare[®]
a prismhealthcare company

The Prime Comfort static mattress is high-resiliency foam offering excellent pressure relief.

The castellated foam aids comfort and air movement inside the mattress, reducing heat build-up.

KEY FEATURES & BENEFITS

- Excellent comfort and support
- Four-way stretch, water resistant, anti-bacterial PU cover with welded seams and a crib 5 fire rating
- Additional sizes available upon request
- High risk

3 year warranty



177kg/28st
max user weight



LOW MED HIGH V HIGH

PRESSURE RELIEF RISK

Product Information

Product Code	Description	Mattress Dimensions	Mattress Weight
HSMPRIM	Prime Comfort 900mm Wide	2000(L)x900(W)x150(H)mm	9kg
HSMPRIM.12	Prime Comfort 1200mm Wide	2000(L)x1200(W)x150(H)mm	12kg

PRIME COMFORT PLUS STATIC MATTRESS



harvesthealthcare[®]
a prismhealthcare company

The Prime Comfort Plus static mattress provides excellent patient comfort and support.

A castellated foam core facilitates pressure redistribution and air movement inside the mattress, reducing heat build-up. It has a firm foam side wall encasing a resilient central insert, enhancing stability and assisting patient transfer.

Slots in the base enable the mattress to profile.

KEY FEATURES & BENEFITS

- Excellent comfort and support
- Slots in the base enable profiling
- Four-way stretch, water resistant, anti-bacterial PU cover with welded seams and a crib 5 fire rating
- Additional sizes available upon request
- High risk

3 year warranty



247kg/39st
max user weight



LOW MED HIGH V HIGH

PRESSURE RELIEF RISK

Product Information

Product Code	Description	Mattress Dimensions	Mattress Weight
HSMPRIMP	Prime Comfort Plus 900mm Wide	2000(L)x900(W)x150(H)mm	13kg
HSMPRIMP.12	Prime Comfort Plus 1200mm Wide	2000(L)x1200(W)x150(H)mm	17kg

REFLECT 2 STATIC MATTRESS



harvesthealthcare
a prismhealthcare company

The Reflect 2 mattress is a profiling mattress with a castellated viscoelastic top and a firm base. The zonal castellations give tailored pressure relief and allow airflow through the mattress, improving the skin microclimate.

The castellated viscoelastic foam offers improved immersion and pressure distribution. The firm base gives support and helps with the even distribution of weight. There are keyhole slots in the base to aid profiling.

This comfortable pressure care solution is a dependable staple for plus-sized pressure care.

KEY FEATURES & BENEFITS

- Castellated viscoelastic top and firm foam base
- Slots in the base enable profiling
- Four-way stretch, water resistant, anti-bacterial PU cover with welded seams and a crib 5 fire rating
- Available in 2 different weight limits
- High risk

3 year warranty



LOW MED HIGH V HIGH

PRESSURE RELIEF RISK

Product Information

Product Code	Description	Mattress Dimensions	Max. Patient Weight
HFR147	Reflect 2, 900mm Wide	2000(L)x900(W)x165(H)mm	47kg/39st
HFR147.12	Reflect 2, 1200mm Wide	2000(L)x1200(W)x165(H)mm	247kg/39st
HFR147.1370	Reflect 2, 1370mm Wide	2000(L)x1370(W)x165(H)mm	247kg/39st
HFR227	Reflect 2 Plus Size 45st 1200mm Wide	2000(L)x1200(W)x180(H)mm	285kg/45st
HFR227.14	Reflect 2 Plus Size 45st 1400mm Wide	2000(L)x1400(W)x180(H)mm	285kg/45st
HFR227.60	Reflect 2 Plus Size 60st 1200mm Wide	2000(L)x1200(W)x180(H)mm	381kg/60st
HFR227.1400.60	Reflect 2 Plus Size 60st 1400mm Wide	2000(L)x1400(W)x180(H)mm	381kg/60st

FIRE-TECH 7 COMFORT STATIC MATTRESS



harvesthealthcare[®]
a prismhealthcare company

The Fire-Tech 7 Comfort is a pressure care static mattress for environments with increased fire risk. The mattress has a Crib 7 fire rating, the industry's most demanding fire test.

It provides excellent pressure redistribution and comfort for patients at high risk of developing a pressure-related injury.

KEY FEATURES & BENEFITS

- Excellent comfort and support
- Four-way stretch, waterproof, anti-bacterial PU cover
- Available welded or zipped
- Crib 7 fire rating
- Additional sizes available upon request
- High risk

3 year warranty



190kg/30st
max user weight



LOW MED HIGH V HIGH

PRESSURE RELIEF RISK

Product Information

Product Code	Description	Mattress Dimensions	Mattress Weight
HSMFIRET.CFT	Fire-Tech 7 Comfort 900mm Wide	2000(L)x900(W)x150(H)mm	8.5kg
HSMFIRET.CFT.W	Fire-Tech 7 Comfort Welded Cover	2000(L)x900(W)x150(H)mm	8.5kg
HSMFIRET.CFT.12	Fire-Tech 7 Comfort 1200mm Wide	2000(L)x1200(W)x150(H)mm	11kg

FIRE-TECH 7 STATIC MATTRESS



harvesthealthcare[®]
a prismhealthcare company

The Fire-Tech 7 Static Mattress is a vandal-proof mattress for challenging environments at increased fire risk.

KEY FEATURES & BENEFITS

- Block foam in the base
- Anti-bacterial PU cover with welded seams
- Crib 7 fire rating
- Additional sizes available upon request



Product Information

Product Code	Description	Mattress Dimensions	Mattress Weight
HSMFIRE7.VP	Fire-Tech 7 900mm Wide Vandal Proof	2000(L)x900(W)x150(H)mm	8.5kg

DIVAN MATTRESS



harvesthealthcare
a prismhealthcare company

The Divan mattress is an affordable, comfortable option for those in need of a non-profiling mattress.

Covered with a cotton, woven material, the mattress also has a PVC, water resistant coating which allows the mattress to breathe. This is important, as the foam within will last longer and regain shape after use.

The Divan mattress includes:

- 13.5 gauge
- 3 inch diameter springs

Please note, the mattress has no pressure relieving properties and is not suitable for a profiling bed. The vandal proof and Fire-Tech versions of this mattress are also available on request for challenging environments, or environments at increased risk of fire.

TURNING

The National Bed Federation recommends that all mattresses be turned once a month to allow for even wear on the fillings and prevent mattress settlement. Turning a mattress is a condition of our manufacturer's warranty and may invalidate the warranty if this is not done.

CLEANING

The mattress should be wiped down with mild disinfectant and water. Do not use neat disinfectant, as this will eventually affect the waterproof membrane. The mattress should not be left for a long time with incontinent patients on them as in extreme cases, fluid has been known to seep to the edges of the mattress and through the tape edging.



127kg/20st
max user weight



Our Divan bed is a great affordable option for your nursing home or community residents who do not need a profiling bed.

Product Information

Product Code	Description	Dimensions
HLB709	Divan Bed Base	1900(L)x930(W)x370(H)mm
HLB708	Divan Mattress	1900(L)x930(W)x160(H)mm
HLB7092	Divan Bed Headboard	900mm(W)

SYSTEM RANGE STATIC MATTRESSES



The System range is made of high-quality moulded foam, offering high maximum patient weights and risk levels. Extra features create superior levels of comfort and pressure relief.

Anatomical Shape Insert

Regular Viscoelastic Foam Mattress

The viscoelastic foam is strongly compressed in the area at risk, especially when profiled.

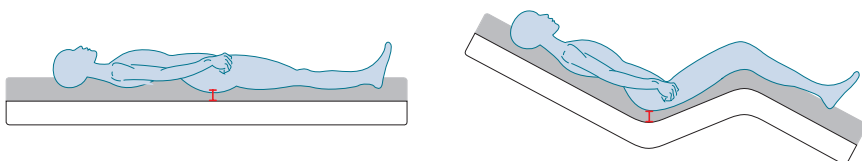

System Mattresses

As the insert follows the body shape in the sacrum area, the thickness of the viscoelastic foam is maximised to foster better prevention in areas at risk.

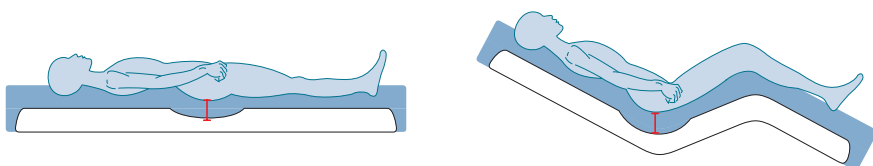

Multibearing Evolutive Concept

The multi-bearing surface enables a better pressure distribution by transferring support from areas with the low bearing capacity to areas with high bearing capacity.

White Area:

Areas with low bearing capacity (softer foam) give increased prevention to areas at risk of pressure ulcerations (heels).

Blue Areas

Areas with high bearing capacity (firmer foam) for areas of the body with a lower level of pressure ulceration risk.

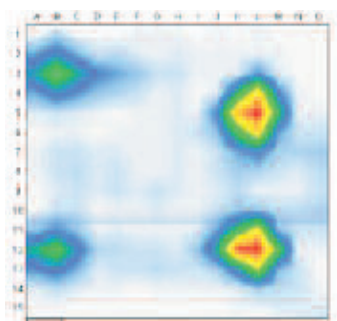

Viscoelastic Foam
Mattress

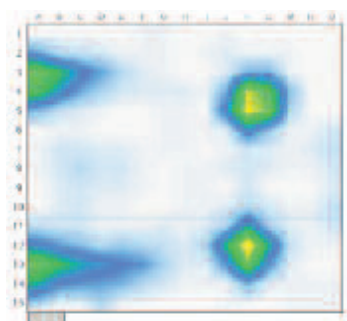

Viscoflex
Evolutive



Pressure
Transfer

VISCOFLEX STATIC MATTRESS



harvesthealthcare
a prismhealthcare company

The Viscoflex is a high-resilience mattress moulded to ensure bonding. The mattress has an anatomically shaped base with a memory foam top.

The high-density top increases the contact area and improves pressure distribution with increased depth in sacral regions. The high-density base works with the top to enhance support and comfort.

KEY FEATURES & BENEFITS

- Very high-density viscoelastic foam
- Uniquely shaped to accommodate bed accessories
- Four-way stretch, waterproof, anti-bacterial PU coated cover with welded seams and a crib 5 fire rating
- Comes with a 3-year warranty
- High to very high risk

3 year warranty

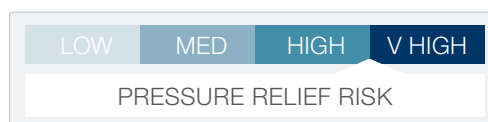

Product Information

Product Code	Description	Mattress Dimensions	Max Patient Weight
P161MFPMHF	Viscoflex 860mm Wide	1990(L)x860(W)x140(H)mm	130kg/20st
P161MFPMHF120	Viscoflex 1200mm Wide	2000(L)x1200(W)x140(H)mm	270kg/42st

VISCOFLEX MULTI BEARING STATIC MATTRESS



harvesthealthcare[®]
a prismhealthcare company

The Viscoflex Mattress with Multi-bearing Surface has all the great features of the Viscoflex mattress with an added multi-bearing surface.

The multi-bearing surface enables better pressure distribution by transferring supports from the areas of low bearing capacity toward regions with high bearing capacity. White areas with low bearing capacity (softer foam) give increased prevention to areas at risk of pressure ulcerations (heels). Blue areas with high bearing capacity (firmer foam) are for areas of the body with a lower level of pressure ulceration risk.

KEY FEATURES & BENEFITS

- Very high-density viscoelastic foam
- Added multi-bearing surface
- Uniquely shaped to accommodate bed accessories
- Four-way stretch, water resistant, anti-bacterial PU coated cover with welded seams and a crib 5 fire rating
- Very high risk

3 year warranty



130kg/20st
max user weight



LOW MED HIGH V HIGH

PRESSURE RELIEF RISK

Product Information

Product Code	Description	Mattress Dimensions
P161MFPPMHF	Viscoflex Multi Bearing 860mm Wide	1990(L)x860(W)x140(H)mm

VISCOFLEX EVOLUTIVE STATIC MATTRESS



harvesthealthcare
a prismhealthcare company

The Viscoflex Evolutive static mattress is our enhanced mattress in the Viscoflex range.

Positioning specialist foam inserts across key areas of the mattress allows for more pressure relief and comfort. The varying firmness in the foam at zonal regions contributes to the additional support. The visco-elastic memory foam moulds to the users' body shape, and the high resilience foam base increases stability.

The multi-bearing surface enables better pressure distribution through the transfer of support from the areas of low bearing capacity toward regions with high bearing capacity.

KEY FEATURES & BENEFITS

- Very high-density viscoelastic foam
- Added multi-bearing surfaces
- Uniquely shaped to accommodate bed accessories
- Supplied with a four-way stretch, fully welded, waterproof, PU-coated, polyester cover
- Very high risk

3 year warranty



130kg/20st
max user weight



LOW MED HIGH V HIGH

PRESSURE RELIEF RISK

Product Information

Product Code	Description	Mattress Dimensions
P161MFEPMHF	Viscoflex Evolutive 860mm Wide	1970(L)x860(W)x140(H)mm

KINETIC AIR HYBRID MATTRESS



harvesthealthcare
a prismhealthcare company

The Kinetic Air hybrid mattress is a replacement mattress system combining air displacement technologies with the benefits of a static foam mattress.

A castellated foam top and high resilience base aid in comfort and support for the patient. The walls of the mattress provide additional support by containing the foam core.

As the patient moves, internal air pressure is redistributed through a system of valves. This redistribution prevents the patient from overheating whilst laying on the mattress, as the foam can breathe.

KEY FEATURES & BENEFITS

- Suitable for fully profiling beds
- Castellated visco foam top and high resilience foam base and walls
- Combination of softer and firmer cells at key locations for full and comfortable support
- Fully welded, antibacterial, water resistant, four-way stretch cover
- High risk

3 year warranty



247kg/39st
max user weight



LOW MED HIGH V HIGH

PRESSURE RELIEF RISK

Product Information

Product Code	Description	Mattress Dimensions
HFk100	Kinetic Air Hybrid Mattress	2000L)x900(W)x150(H)mm

PRIME COMFORT ACTIVE HYBRID MATTRESS



harvesthealthcare[®]
a prismhealthcare company

The Prime Comfort Active mattress combines all the benefits of our Prime Comfort Plus mattress plus so much more. The addition of cells allows stepping up or down patient care with or without a pump.

Built using both static foam and alternating air cells, the mattress can be used with or without the pump. This combination means patients at a very high risk of developing pressure ulcers will still be protected when the mattress is deflated.

Harvest 1 pump can be purchased separately.

KEY FEATURES & BENEFITS

- Firm 'U' shaped high-density foam base for roll prevention and to aid transfers
- Castellated soft and resilient central foam insert
- 10 alternating cells powered by the low noise level pump
- Fully welded, antibacterial, water resistant, four-way stretch cover
- Durable PVC base
- Step up, step down with/without pump
- Compatible with Harvest pumps 1 and 2, allowing for a range of maximum patient weights
- Very high risk with a pump
- High risk without a pump

3 year warranty



247kg/39st
max user weight

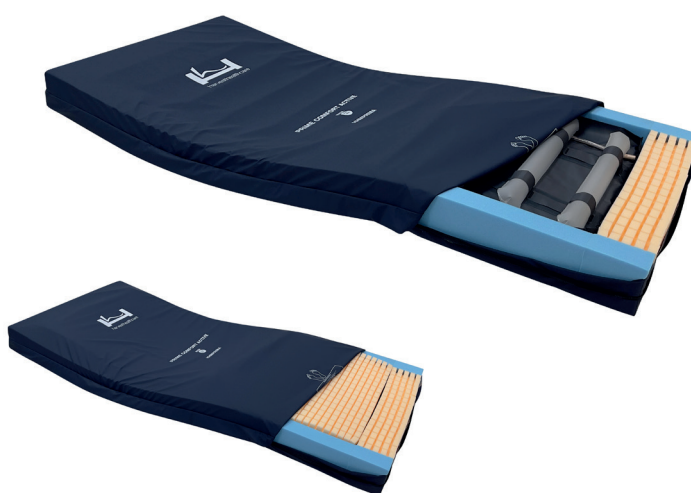

LOW MED HIGH V HIGH

PRESSURE RELIEF RISK

Compatible with:



The Harvest 1
pump

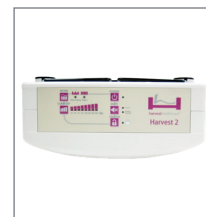

The Harvest 2
pump



Pump Grip (Small - Compatible with Harvest 1 Pump) - PU115

Pump Grip (Large - Compatible with Harvest 2 Pump) - PU215

Product Information

Product Code	Description	Mattress Dimensions	Mattress Weight
HHMPRIMA.P1	Prime Comfort Active only for Harvest 1 Pump	2000(L)x900(W)x140(H)mm	9kg
HHMPRIMA.P2	Prime Comfort Active only for Harvest 2 Pump	2000(L)x900(W)x140(H)mm	9kg

KENSINGTON OVERLAY ACTIVE MATTRESS



The Kensington Active Mattress is Harvest Healthcare's alternating overlay mattress, designed for patients at high risk of developing pressure ulcers. This active overlay is intended for the patient's static mattress. It should not be used on its own.

The Kensington is light and easily manoeuvrable. Suppose you have many patients in need of pressure reduction and relief. This overlay mattress is perfect for community use and provides a cost-effective, high-quality solution.

KEY FEATURES & BENEFITS

- 18 cells: 16 alternating cells made of TPU material to reduce noise when cells inflate and deflate and 2 static cells for patient stability and comfort
- Pillow section for patient stability
- All cells interchangeable for ease of repair and cleaning
- Low weight to allow the carer to easily move the mattress
- 4-way stretch welded PU cover, which is vapour permeable, water resistant and has a Crib 5 fire rating
- High risk
- Compatible with Harvest pumps 1 and 2, allowing for a range of maximum patient weights
- Mattress weight: 6kg

3 year warranty



LOW MED HIGH V HIGH

PRESSURE RELIEF RISK

Compatible with:



The Harvest 1 pump

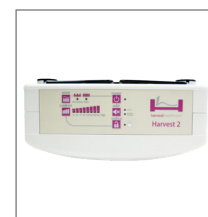

The Harvest 2 pump



Pump Grip (Small - Compatible with Harvest 1 Pump) - PU115
Pump Grip (Large - Compatible with Harvest 2 Pump) - PU215

Product Information

Product Code	Description	Mattress Dimensions	Max. Patient Weight
HAMKENS001.P1	Kensington Overlay only for Harvest 1 Pump	2000(L)x900(W)x110(H)mm	158kg/25st
HAMKENS001.P2	Kensington Overlay only for Harvest 2 Pump	2000(L)x900(W)x110(H)mm	184kg/29st

SANDRINGHAM REPLACEMENT ACTIVE MATTRESS



harvesthealthcare[®]
a prismhealthcare company

The Sandringham Active Mattress is Harvest Healthcare's basic replacement mattress with 18 alternating cells and an integral 50mm foam layer providing an overall depth of 160cm. A pillow section has 2 static cells for stability and comfort. The cells are made of TPU material to reduce noise disturbance when cells alternately inflate and deflate on a 10-minute cycle.

This product is easy to maintain with interchangeable cells and provides the customer with excellent value for money when choosing an alternating mattress replacement to achieve pressure reduction for high-risk patients in long-term care.

KEY FEATURES & BENEFITS

- 18 cells: 16 alternating cells made of TPU material to reduce noise when cells inflate and deflate and 2 static cells for patient stability and comfort
- 50mm insert of high-quality foam
- Pillow section for patient stability
- All cells interchangeable for ease of repair and cleaning
- Low weight to allow the carer to easily move the mattress
- 4-way stretch welded PU cover, which is vapour permeable, water resistant and has a Crib 5 fire rating
- High risk
- Compatible with Harvest pumps 1 and 2, allowing for a range of maximum patient weights
- Mattress weight: 9kg

3 year warranty



LOW MED HIGH V HIGH

PRESSURE RELIEF RISK

Compatible with:



The Harvest 1 pump

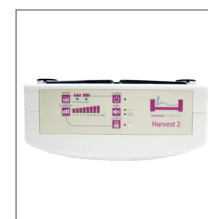

The Harvest 2 pump



Pump Grip (Small - Compatible with Harvest 1 Pump) - PU115

Pump Grip (Large - Compatible with Harvest 2 Pump) - PU215

Product Information

Product Code	Description	Mattress Dimensions	Max. Patient Weight
HAMSAND001.P1	Sandringham Mattress only for Harvest 1 Pump	2000(L)x900(W)x160(H)mm	158kg/25st
HAMSAND001.P2	Sandringham Mattress only for Harvest 2 Pump	2000(L)x900(W)x160(H)mm	184kg/29st

HAMPTON REPLACEMENT ACTIVE MATTRESS



harvesthealthcare
a prismhealthcare company

The Hampton is Harvest Healthcare's durable active replacement mattress, designed to prevent and manage pressure ulcers in patients at very high risk. It is also recommended to treat up to stage 4 of pressure ulcers.

The mattress is made up of 20 individual cells. 17 alternating air cells and 3 static pillow section cells. The cells are made of TPU material to reduce noise disturbance when cells alternately inflate and deflate on a 10-minute cycle.

The Hampton mattress is an all-rounder for comfort and pressure area care solutions.

KEY FEATURES & BENEFITS

- 20 cells made of TPU material to reduce noise when cells inflate and deflate
- Pillow section for patient stability and comfort
- All cells interchangeable for ease of repair and cleaning
- 4-way stretch welded PU cover, which is vapour permeable, water resistant and has a Crib 5 fire rating
- Very high risk
- Compatible with all Harvest pumps, allowing for a range of maximum patient weights
- Mattress weight: 8kg

3 year warranty



LOW MED HIGH V HIGH

PRESSURE RELIEF RISK

Compatible with:



The Harvest 1 pump

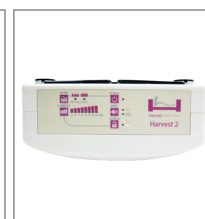

The Harvest 2 pump



The Harvest 3 pump



Pump Grip (Small - Compatible with Harvest 1 Pump) - PU115

Pump Grip (Large - Compatible with Harvest 2 Pump) - PU215

Product Information

Product Code	Description	Mattress Dimensions	Max. Patient Weight
HAMHAMP001.P1	Hampton Mattress only for Harvest 1 Pump	2000(L)x900(W)x200(H)mm	158kg/25st
HAMHAMP001.P2	Hampton Mattress only for Harvest 2 Pump	2000(L)x900(W)x200(H)mm	184kg/29st
HAMHAMP001.P3	Hampton Mattress only for Harvest 3 Pump	2000(L)x900(W)x200(H)mm	254kg/40st

WINDSOR REPLACEMENT ACTIVE MATTRESS



The Windsor is Harvest Healthcare's active replacement mattress designed to prevent and manage pressure ulcers in patients at very high risk.

The mattress has 17 alternating air cells and 3 static pillow section cells for patient stability.

The Windsor mattress is an all-rounder for pressure area care solutions. Being made of a very soft and quiet material, it has the critical factors to gain patient cooperation and concordance with pressure reduction therapy. It provides high levels of comfort and pressure care for users who find other alternating mattresses uncomfortable.

KEY FEATURES & BENEFITS

- 20 cells made of pure PU, a softer and quieter material for patient comfort
- The base sheet is a super easy wipe-down material and has a Crib 5 fire rating
- Pillow section for patient stability
- All cells interchangeable for ease of repair and cleaning
- 4-way stretch welded PU cover, which is vapour permeable, welded, water resistant and has a Crib 5 fire rating
- The PU resists water to make the cells easier to clean
- Very high risk
- Compatible with Harvest 2 and Harvest 3 pumps
- Cable management system
- Mattress weight: 10kg

3 year warranty



LOW MED HIGH V HIGH
PRESSURE RELIEF RISK

Compatible with:

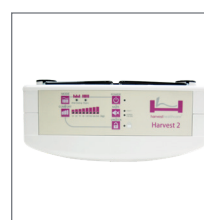

The Harvest 2 pump



The Harvest 3 pump



Pump Grip (Large - Compatible with Harvest 2 Pump) - PU215

Product Information

Product Code	Description	Mattress Dimensions	Max. Patient Weight
HAMWIND001.P2	Windsor Mattress only for Harvest 2 Pump	2000(L)x900(W)x200(H)mm	184kg/29st
HAMWIND001.P3	Windsor Mattress only for Harvest 3 Pump	2000(L)x900(W)x200(H)mm	254kg/40st

BALMORAL REPLACEMENT ACTIVE MATTRESS



harvesthealthcare[®]
a prismhealthcare company

The Balmoral Replacement is Harvest Healthcare's top-of-the-range pressure-reducing active mattress used to prevent and manage pressure ulcers. It is recommended for use by a patient at very high risk of developing pressure ulcers and for treating up to stage 4 pressure ulcers.

It comprises 27 individual cells: 23 alternating air cells, and 4 static pillow section cells, on a 50mm thick foam layer. Cells are made of pure PU and interchangeable for easy repair and cleaning. In addition, the mattress is designed to ensure bedrail compliance on any UK-manufactured profiling bed.

KEY FEATURES & BENEFITS

- 27 individual cells made of pure PU, a softer and quieter material for patient comfort
- The mattress has an integrated foam base
- Pillow section for patient stability
- All cells are interchangeable for ease of repair and cleaning
- 4-way stretch welded PU cover, which is vapour permeable and water resistant and has a Crib 5 fire rating
- Compatible with Harvest pumps 2 and 3
- Very high risk
- Mattress weight: 8kg

3 year warranty



LOW MED HIGH V HIGH

PRESSURE RELIEF RISK

Compatible with:

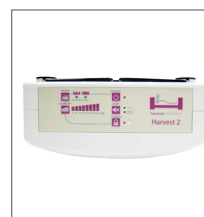

The Harvest 2 pump



The Harvest 3 pump



Pump Grip (Large - Compatible with Harvest 2 Pump) - PU215

Product Information

Product Code	Description	Mattress Dimensions	Max. Patient Weight
HAMBALM001.P2	Balmoral Mattress only for Harvest 2 Pump	2000(L)x880(W)x150(H)mm	184kg/29st
HAMBALM001.P3	Balmoral Mattress only for Harvest 3 Pump	2000(L)x880(W)x150(H)mm	254kg/40st

DUKE REPLACEMENT ACTIVE MATTRESS



harvesthealthcare
a prismhealthcare company

The Duke Active Mattress is a high-quality replacement mattress designed for a frail user vulnerable to developing pressure ulcers. The system provides a high degree of pressure relief while protecting the user. It is recommended for use by a patient at very high risk of developing pressure ulcers and for treating up to stage 4 pressure ulcers.

The mattress comprises 25 alternating air cells and 5 static pillow section cells. A 50mm integral foam base rests beneath the removable cell structure, providing more support and redistributing pressure where necessary.

KEY FEATURES & BENEFITS

- 30 independent cells provide more comfort and support
- Alternating pressure relief distributes the body weight of the service user to provide treatment for pressure ulcers
- Pillow section for patient stability
- All cells interchangeable for ease of repair and cleaning
- 4-way stretch welded PU cover, which is vapour permeable, welded, water resistant and has a Crib 5 fire rating
- The PU resists water to make the cells easier to clean
- Very high risk
- Substantial pressure relief for service users
- Compatible with Harvest 2 and Harvest 3 pumps
- Cable management system
- Mattress weight: 9kg

3 year warranty

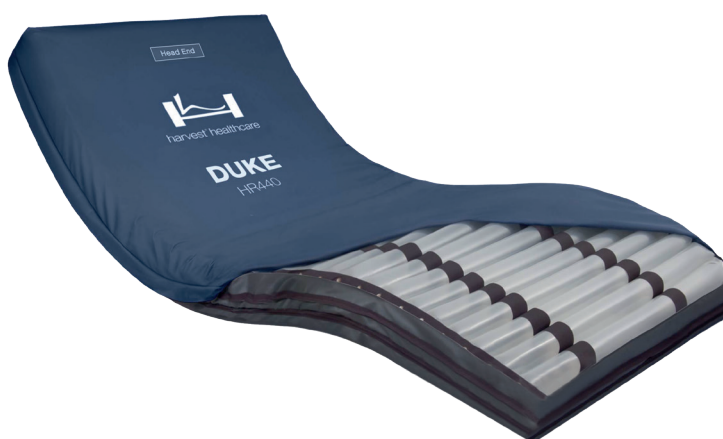

LOW MED HIGH V HIGH

PRESSURE RELIEF RISK

Compatible with:

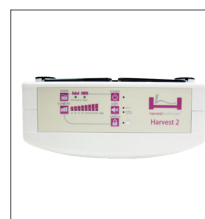

The Harvest 2 pump



The Harvest 3 pump



Pump Grip (Large - Compatible with Harvest 2 Pump) - PU215

Product Information

Product Code	Description	Mattress Dimensions	Max. Patient Weight
HR440.P2	Duke Mattress only for Harvest 2 Pump	1980(L)x900(W)x140(H)mm	165kg/26st
HR440.P3	Duke Mattress only for Harvest 3 Pump	1980(L)x900(W)x140(H)mm	247kg/39st

PARTNERSHIP ACTIVE MATTRESS



harvesthealthcare[®]
a prismhealthcare company

The Partnership is a double-sized active mattress comprising both foam and alternating air cells – one on either side. Half includes viscoelastic foam, which provides pressure reduction, comfort and support for the patient. The alternating air cells make up the other half, with a 10-minute cell cycle of inflation and deflation to provide appropriate pressure reduction.

This is the perfect mattress for high-risk patients with a double bed who require a solution for pressure reduction and relief to prevent or promote the healing of pressure ulcers. The foam section provides comfort and support for the patient's partner, while the alternating cells provide pressure reduction and relief.

KEY FEATURES & BENEFITS

- 15 independent cells
- Alternating pressure relief
- Visco topped static mattress and foam walls
- Maintains quality of life
- Removable cell structure aids in decontamination
- Electronic pressure control
- Timed static mode
- Low running costs
- Quiet Operation
- CPR quick-release facility
- 4-way stretch welded PU cover, which is vapour permeable, welded, water resistant and has a Crib 5 fire rating
- High risk
- Compatible with Harvest 1 and Harvest 2 pumps

3 year warranty



LOW MED HIGH V HIGH

PRESSURE RELIEF RISK

Compatible with:



The Harvest 1
pump

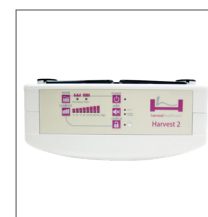

The Harvest 2
pump



Pump Grip (Small - Compatible with Harvest 1 Pump) - PU115

Pump Grip (Large - Compatible with Harvest 2 Pump) - PU215

Product Information

Product Code	Description	Mattress Dimensions	Max. Patient Weight
HS500.P1	Partnership Mattress only for Harvest 1 Pump	1980(L)x1370(W)x180(H)mm	158kg/25st
HS500.P2	Partnership Mattress only for Harvest 2 Pump	1980(L)x1370(W)x180(H)mm	184kg/29st

HAMPTON EXTRA REPLACEMENT PLUS SIZE ACTIVE MATTRESS



harvesthealthcare
a prismhealthcare company

The Hampton Extra replacement is Harvest Healthcare's plus size active mattress. Designed for plus-size patients at very high risk of developing pressure ulcers.

It has 17 alternating cells made of Nylon with a TPU lining to reduce noise when the cells inflate and deflate and a pillow section with 3 static cells for patient stability.

The foam surround allows for a broader mattress to be used on a 1200-wide bed, like the Community 1200 and the Ultimate 1200 and provides extra stability for transfers. It also improves stability when transferring from bed to chair and prevents bottoming out. This mattress is essential for those wanting to provide the right equipment for plus-size patients.

KEY FEATURES & BENEFITS

- 20 cells made of Nylon with a TPU lining to reduce noise when cells inflate and deflate
- Pillow section for patient stability
- All cells interchangeable for ease of repair and cleaning
- 4-way stretch welded PU cover, which is vapour permeable, water resistant and has a Crib 5 fire rating
- Foam surround
- Very high risk
- Compatible with Harvest 3 pump

3 year warranty



LOW MED HIGH V HIGH

PRESSURE RELIEF RISK

Compatible with:



The Harvest 3 pump

Product Information

Product Code	Description	Mattress Dimensions	Max. Patient Weight
HAMHAMP002.P3	Hampton Extra Mattress only for Harvest 3 Pump	2000(L)x1200(W)x230(H)mm	317kg/50st

DUKE EXTRA 2.0 REPLACEMENT PLUS SIZE ACTIVE MATTRESS



The Duke Extra 2.0 is an alternating pressure-relieving mattress system used to prevent and treat pressure ulcers. It is recommended for use by a patient at very high risk of developing pressure ulcers and for treating up to stage 4 pressure ulcers.

The mattress comprises 25 alternating air cells and 4 static pillow section cells at the head end. With a maximum patient weight of 50 Stone, this mattress suits larger patients.

Edge-to-edge alternating cells reduce pressure across the entire width of the mattress, offering alternating pressure care at all points. It has been designed to fit the broader beds in our product range, such as the Community 1200 and the Ultimate 1200 wide profiling beds.

KEY FEATURES & BENEFITS

- 29 cells provide more comfort and support
- Alternating pressure relief
- CPR rapid deflation valve
- 4-way stretch welded PU cover, which is vapour permeable, water resistant and has a Crib 5 fire rating
- Quiet operation
- Electronic pressure control
- Very high risk
- Compatible with Harvest 3 pump

3 year warranty



Compatible with:



The Harvest 3 pump

Product Information

Product Code	Description	Mattress Dimensions	Max. Patient Weight
HAMDUKE.12.P3	Duke Extra 2.0 Mattress only for Harvest 3 Pump	2000(L)x1200(W)x200(H)mm	317kg/50st

WONDERMAT ACTIVE MATTRESS



The Wondermat Active Mattress is designed to constantly maintain interface pressures below capillary closure powered by the Wondermat pump for very high-risk patients.

The low air loss Wondermat Replacement System is designed to maintain low interface pressures to prevent capillary closure.

This mattress is aimed at patients at the highest risk of developing pressure ulcers and moisture damage and who need equipment that is right for them in terms of pressure reduction and relief, control of moisture, and optimised comfort.

KEY FEATURES & BENEFITS

- Rapid auto firm
- Tri-zonal feature
- Fowler mode
- Electronic pressure control
- Lockout to avoid unauthorised changes to settings
- Low pressure/power failure visual and audible alarms
- Self-diagnosis check
- CPR quick-release facility
- Complete with quilted vapour permeable water-resistant cover
- Transport facility
- Powered by the Wondermat pump
- Suitable for fully profiling beds
- Very high risk

3 year warranty



LOW MED HIGH V HIGH

PRESSURE RELIEF RISK

Product Information

Product Code	Description	Mattress Dimensions	Max. Patient Weight
HW600	Wondermat Active System with Wondermat Pump	2060(L)x900(W)x220(H)mm	190kg/30st

ROTATIONAL ACTIVE MATTRESS



harvesthealthcare
a prismhealthcare company

The Rotational Active Mattress is a high-quality, replacement active mattress system that offers three-in-one therapy to effectively prevent pressure ulcers. This includes lateral turning therapy, alternating therapy, and continuous low-pressure therapy. The mattress is designed to assist with pulmonary complications and treat pressure ulcers. It is suitable for patients in need of regular re-positional changes where this cannot be achieved by the patient or carers.

During lateral turning therapy, the carer can achieve easier repositioning with support from the mattress. The mattress helps facilitate postural drainage, especially for immobile patients. Also, alternating therapy can be activated simultaneously during lateral turning therapy. This function improves circulation and skin reperfusion and provides effective pressure relief via selectable cycle time. The continuous low-pressure therapy can provide body immersion for optimal comfort as a larger skin area will be supported by lower air pressure. This active mattress can significantly lower the risk of pressure ulcers while helping carers facilitate repositioning with this automatic system. Full training on use is provided by the team at Harvest, and this system is compatible with the Harvest profiling beds.

KEY FEATURES & BENEFITS

- Up to 30° of bilateral turning therapy to assist patient repositioning and enhance pressure relief
- Offering extra support in the sacral area when in and during a sitting position
- Fast inflation time & electronic pressure control
- Heel pressure relief function
- Improving circulation & skin reperfusion
- Lockout to avoid unauthorised changes to settings
- Low pressure/power failure visual and audible alarms
- CPR quick-release facility
- Complete with low friction and sheer vapour permeable, high flame retardant, water-resistant cover
- Transport mode
- Cable management for a safe operational environment
- Suitable for fully profiling beds
- High to very high risk

3 year warranty

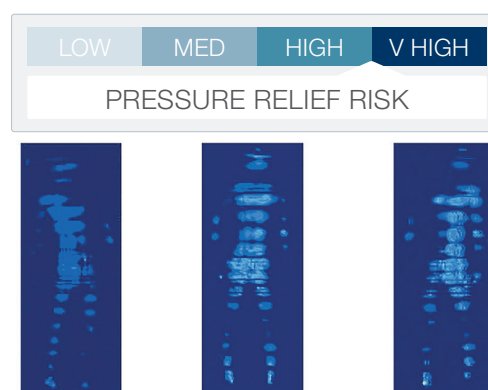

Pressure Mapping of 30° bilateral turning (weight 75kg)

Product Information

Product Code	Description	Mattress Dimensions	Max. Patient Weight
HR800	Rotational Active Mattress with Pump	2000(L)x900(W)x250(H)mm	180kg/28st
Pump Dimensions	Pump Weight	Pump Voltage	Pump Cycle Time
341 x 165 x 260mm	4.5kg	AC230v/50Hz	10, 15, 20, 25 min.
			Pressure Setting
			LED



harvesthealthcare
a prismhealthcare company

HARVEST 1 PUMP

The Harvest 1 Pump is Harvest Healthcare's manually operated pump. It is ideal for care home settings as it has a simple interface with a dial. It is easy to connect and disconnect and is lightweight, creating ease of use for the carer. It has visual and audible low-pressure alarms for safety.



Product Information

Product Code	Dimensions	Pump Weight	Cycle Time	Air Flow Output	Pressure Setting
HPU1	100 x 130 x 280mm	1.7kg	10 minutes	7 lpm	Manual

PUMP POWER REQUIREMENTS

Power rating: 8W- Voltage: AC230v/50Hz- Fuse:1A
Electrical Safety Standard: EN 60601-1. EN 60601-1-2

HARVEST 2 PUMP

The Harvest 2 is Harvest Healthcare's digital pump. It is ideal for use in community and care home settings as it is easy to use. It has a power failure alarm, L.E.D display, lock-out mode and static mode.



Product Information

Product Code	Dimensions	Pump Weight	Cycle Time	Air Flow Output	Pressure Setting
HPU2	130 x 140 x 270mm	1.7kg	10 minutes	9 lpm	LED

PUMP POWER REQUIREMENTS

Power rating: 9VA - Voltage: AC230v/50Hz - Fuse: T 1AH 250V
Electrical Safety Standard: EN 60601-1. EN 60601-1-2

HARVEST 3 PUMP

The Harvest 3 Pump is Harvest Healthcare's high-end digital pump. It is ideal for use in all settings, including acute. It caters for plus-size products and more complex clinical needs. It is easy to use and has an L.E.D display, lock-out mode, static mode, maxi firm mode, 4 cycle times and visual and audible low-pressure alarms for safety.



Product Information

Product Code	Dimensions	Pump Weight	Cycle Time	Air Flow Output	Pressure Setting
HPU3	340 x 125 x 220mm	3.5kg	10/15/20/ 25 min	12 lpm	LED

PUMP POWER REQUIREMENTS

Power rating: 8W- Voltage: AC230v/50Hz- Fuse:T1A 250v- Pressure range: 20-765mmHg
Electrical Safety Standard: EN 60601-1. EN 60601-1-2

FALL MATS UNDERLAYS AND OVERLAYS



harvesthealthcare[®]
a prismhealthcare company

FOLDING FALL MAT

The Harvest Folding Fall Mat offers the same level of safety as the standard fall mat, with additional advantages.

Manufactured using similar foam as our static mattresses, in the event of a patient fall, a soft landing is provided. This particular fall mat can be folded and stored away when not used.

Fall mats are ideal for patients in Low or Ultra Low Beds; with the beds closer to the floor, the patients can roll onto the fall mat.

The fall mats have a vapour-permeable cover and a non-slip base.

Product Information

Product Code	Dimensions
HFM104NS	1800(L)x640(W)x64(H)

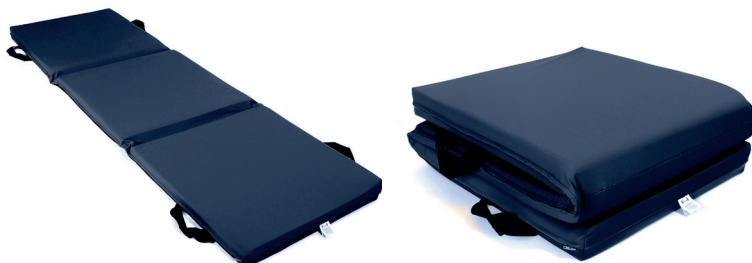

FALL MATS

risk of rolling. Should users be in a Woburn Low or Woburn Ultra-Low Bed without side rails, the fall mat will provide a soft landing should they roll too far. Available in various sizes.

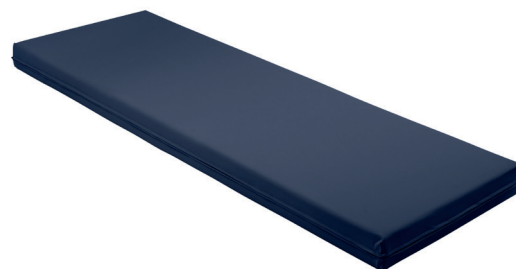

Product Information

Product Code	Description	Dimensions	Max. Weight
HFO122	Modular Foam Overlay	1880(L)x865(W)x95(H) mm	114kg/18st
HFO119	Modular Foam Overlay	1900(L)x1370(W)x95(H) mm	114kg/18st
HFU110	50mm White Foam Underlay	2000(L)x900(W)x50(H) mm	
HFC102	Standard Fall Mat	1830(L)x610(W)x100(H) mm	
HFC103	Standard Fall Mat	1420(L)x815(W)x64(H) mm	

COMMUNITY MODULAR FOAM CUSHION



The Community Modular Foam Cushion combines stability with a high comfort level, offering the user more than expected. The cushion is cut with specific castellations and has a highly breathable foam to prevent the user from becoming too hot. The cushion has a zipped, vapour-permeable, four-way stretch cover with an anti-slip base.

KEY FEATURES & BENEFITS

- Castellated block foam
- Zipped, vapour-permeable, water-resistant, four-way stretch cover
- Non-slip base
- Can be paired with our Community mattress for 24- hour pressure care
- Available in 2 different sizes
- Medium risk

3 year warranty

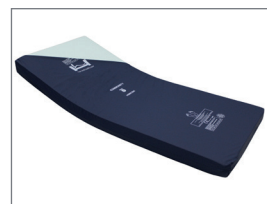

Paired Mattress:
Community (HSMCOM)
Medium Risk - SWL:159kg

Product Information

Product Code	Dimensions	Paired Mattress	Safe Working Load
HFC121	430(L)x430(W)x95(H) mm	Community (HSMCOM)	95kg /15st
HFC116	500(L)x500(W)x95(H) mm	Community (HSMCOM)	108kg/17st

PRIME COMFORT VISCO TOP CUSHION



A 50mm layer of viscoelastic foam tops the standard foam base, transforming the cushion into a high-risk product. The top layer of foam provides extra support and comfort to high-risk patients.

The Prime Comfort Visco Top cushion has a zip with a flap and a four-way stretch cover with an anti-slip base.

KEY FEATURES & BENEFITS

- Foam topped with visco foam
- Zipped with flap, water-resistant, four-way stretch cover
- Non-slip base
- Can be paired with our Prime Comfort mattress for 24-hour pressure care
- Available in 2 different sizes
- High risk

3 year warranty

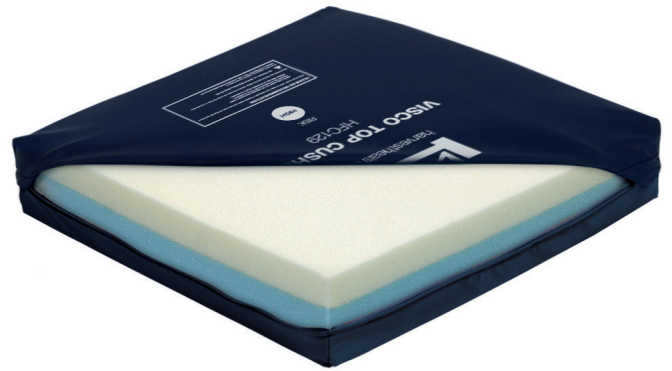

Paired Mattress:
Prime Comfort (HSMPRIM)
High Risk - SWL: 177kg

Product Information

Product Code	Dimensions	Paired Mattress	Safe Working Load
HFC129	430(L)x430(W)x79(H) mm	Prime Comfort (HSMPRIM)	127kg/20st
HFC123	510(L)x510(W)x76(H) mm	Prime Comfort (HSMPRIM)	139kg/22st

PRIME COMFORT PLUS VISCO TOP CUSHION

Standard Static Cushions

64



A high-risk viscoelastic and foam bonded cushion. The improved immersion of visco top and combining a second layer of visco elastic foam and a firm foam base adds support.

The foam combination enhances pressure distribution and combines stability and comfort for high-risk patients.

The Prime Comfort Plus Visco Top cushion has a navy blue, four-way stretch cover with an anti-slip base.

KEY FEATURES & BENEFITS

- Foam topped and bottomed with visco foam
- Welded flap, water-resistant, four-way stretch cover
- Non-slip base
- It can be paired with our Prime Comfort Plus mattress for 24-hour pressure care
- High risk

3 year warranty



Paired Mattress:
Prime Comfort Plus
(HSMPRIMP)
High Risk - SWL: 247kg

Product Information

Product Code	Dimensions	Paired Mattress	Safe Working Load
HFC129.01	430(L)x430(W)x75(H) mm	Prime Comfort Plus (HSMPRIM)	158kg/25st

REFLECT CUSHION

Standard Static Cushions

65



harvesthealthcare[®]
a prismhealthcare company

A castellated, viscoelastic foam layer rests on a high-density foam base. The base gives resilience and stability. The castellations allow the foam to breathe and provide more patient comfort.

The Reflect cushion has a navy blue, four-way stretch, highly breathable cover with an anti-slip base.

KEY FEATURES & BENEFITS

- Castellated visco foam on foam
- Zipped, highly breathable, water resistant, four-way stretch cover
- Non-slip base
- It can be paired with our Reflect 2 mattress for 24-hour pressure care
- High risk

3 year warranty



LOW MED HIGH V HIGH

PRESSURE RELIEF RISK



Paired Mattress:
Reflect 2 (HFR147)
High Risk - SWL: 247kg

Product Information

Product Code	Dimensions	Paired Mattress	Safe Working Load
HFC130	430(L)x430(W)x100(H) mm	Reflect 2 (HFR 147)	127kg/20st

VISCOFLEX PLUS CUSHION

Standard Static Cushions

66



The Viscoflex Plus cushion is a high-density, moulded, viscoelastic cushion with an ergonomically shaped load-bearing core.

The core is shaped to give optimal immersion in sacral/ischial areas, reducing pressure and facilitating blood circulation. The outer foam is moulded to promote stability and increase the contact area. The skin effect of the moulded foam also gives protection from tearing or crumbling.

This ultra-light cushion is specially designed to provide high levels of stability and pressure relief for the user. It is supplied with a vapour-permeable, water-resistant cover.

KEY FEATURES & BENEFITS

- Injected foam
- Welded, water-resistant, four-way stretch cover
- It can be paired with our Viscoflex Multibearing mattress for 24-hour pressure care
- Available in 3 different sizes
- High to very high risk

3 year warranty

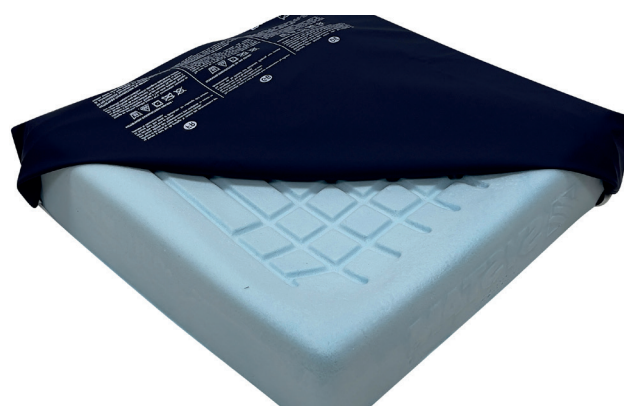

Paired Mattress:
Viscoflex Multibearing
(P161MOPPMHF)

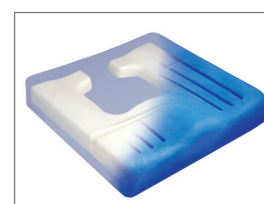

The inside of the
Viscoflex Plus Cushion

High-Very High Risk - SWL: 130kg

Product Information

Product Code	Dimensions	Paired Mattress	Safe Working Load
P361CAF42421HF	420(L)x420(W)x80(H) mm	Viscoflex Multibearing (P161MOPPMHF)	100kg/15st
P361CAF45421HF	450(L)x420(W)x80(H) mm	Viscoflex Multibearing (P161MOPPMHF)	110kg/17st
P361CAF51461HF	510(L)x460(W)x80(H) mm	Viscoflex Multibearing (P161MOPPMHF)	150kg/23st

MIXTE CUSHION



harvesthealthcare[®]
a prismhealthcare company

The Mixte cushion is a combination of gel and foam. Reticulated polyurethane gel avoids migration and thus prevents penetration (punching) of the cushion while assisting pressure distribution.

The thick high-resilience foam base increases the contact area, providing better distribution, comfort and stability. The two layers are permanently bonded together, eliminating the risk of separation.

KEY FEATURES & BENEFITS

- Gel top on foam
- Welded, water-resistant, four-way stretch cover
- It can be paired with our Prime Comfort mattress for 24-hour pressure care
- Medium to high risk

3 year warranty

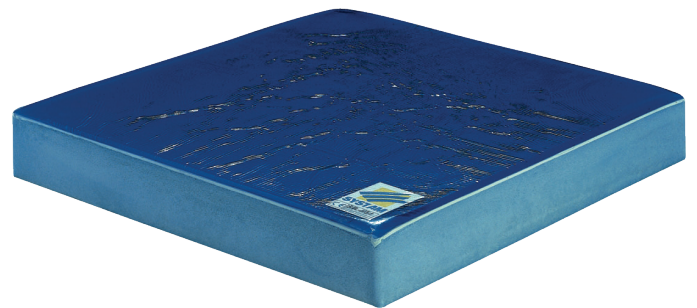

LOW MED HIGH V HIGH

PRESSURE RELIEF RISK



Paired Mattress:
Prime Comfort (HSMPRIM)
High Risk - SWL: 177kg

Product Information

Product Code	Dimensions	Paired Mattress	Safe Working Load
P314C40401HF	400(L)x400(W)x60(H) mm	Prime Comfort (HSMPRIM)	90kg/14st

DUOFORM CUSHION



The Duoform® cushion is an anatomically moulded base of high-resilience foam surmounted by a two-part viscoelastic gel. The white pad fluid gel ensures pressure reduction in high-risk areas. In contrast, the blue viscoelastic gel resists fluid migration, thus preventing penetration and providing added support.

The high-resilience foam base enables the cushion to adapt to bony protuberances, spreads contact surfaces and gives better pressure distribution. It has a highly breathable cover.

KEY FEATURES & BENEFITS

- Anatomically moulded two-part gel on foam
- Welded, four-way stretch, highly breathable cover
- It can be paired with our Prime Comfort Plus mattress for 24-hour pressure care
- Available in 4 different sizes
- Medium to high risk

3 year warranty



LOW MED HIGH V HIGH

PRESSURE RELIEF RISK



Paired Mattress:
Prime Comfort Plus (HSMPRIMP)
High Risk - SWL: 247kg

Product Information

Product Code	Dimensions	Paired Mattress	Safe Working Load
P341C42421HF	420(L)x420(W)x80(H) mm	Prime Comfort Plus (HSMPRIM)	110kg/17st
P341C45421HF	450(L)x420(W)x80(H) mm	Prime Comfort Plus (HSMPRIM)	120kg/18st
P341C45461HF	450(L)x460(W)x80(H) mm	Prime Comfort Plus (HSMPRIM)	120kg/18st
P341C51461HF	510(L)x460(W)x80(H) mm	Prime Comfort Plus (HSMPRIM)	160kg/25st

REFLECT EXTRA CUSHION

Plus Size Static Cushions

69



A layer of castellated, viscoelastic foam rests on a high-density foam base. The base gives resilience and stability. The castellations allow the foam to breathe and provide more patient comfort.

Suitable for plus-size patients, the Reflect Extra cushion has a navy blue, four-way stretch, highly breathable cover with an anti-slip base.

KEY FEATURES & BENEFITS

- Foam topped with viscofoam
- Zipped, water-resistant, four-way stretch cover
- Non-slip base
- It can be paired with our Reflect 2 (HFR227) mattress for 24-hour pressure care
- High risk

3 year warranty

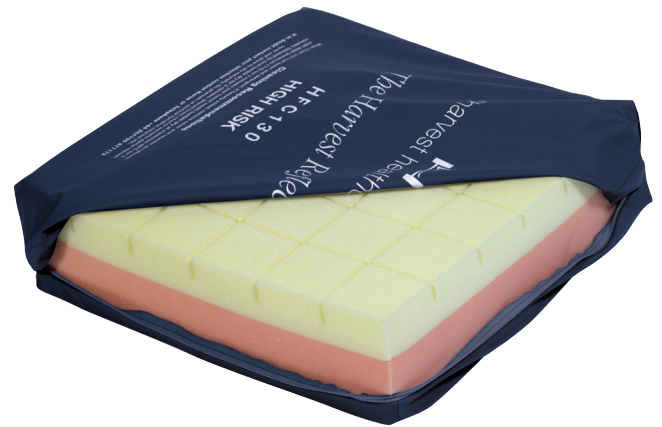

Paired Mattress:
Reflect 2 (HFR227)
High Risk - SWL: 285kg

Product Information

Product Code	Dimensions	Paired Mattress	Safe Working Load
HFC130.EX	510(L)x510(W)x100(H) mm	Reflect 2 (HFR 227)	254kg/39st

VISCOFLEX PLUS BARIATRIC CUSHION

Plus Size
Static Cushions

70



harvesthealthcare
a prismhealthcare company

The innovative Viscoflex Plus Bariatric cushion consists of a moulded Viscoelastic foam with an ergonomic foam insert.

This plus-size cushion is specially designed to provide high levels of stability and pressure relief for the user.

P361CAF56461HF is supplied with a welded, vapour-permeable, water-resistant cover, and P361CA61501HF comes with a welded, vapour-permeable, water-resistant cover with an anti-slip base.

KEY FEATURES & BENEFITS

- Injected foam
- Available in two sizes
- Welded vapour-permeable, water-resistant cover for P361CAF56461HF (560(L)x460(W)x80(H) mm)
- Stitched vapour-permeable, water-resistant cover with an anti-slip base available for P361CA61501HF (610(L)x500(W)x80(H) mm)
- It can be paired with our Viscoflex Bariatric mattress for 24-hour pressure care
- High to very high risk

3 year warranty



With Standard Cushion

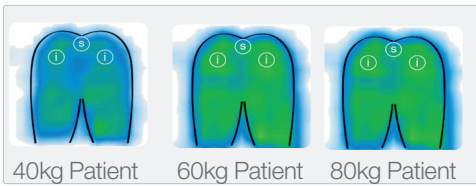

With Viscoflex Plus

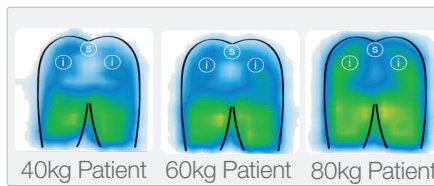

LOW MED HIGH **V HIGH**

PRESSURE RELIEF RISK

ONE
REDUCE THE LOAD ON RISK ZONES

Protected risk zones (sacrum/ischium), even in the cases of pelvic retroversion, in order to provide partial relief of bony protuberances through support.

TWO
ANTI-PUNCHING SYSTEM

Specifically positioned in relation to the ischium. Distributes the pressure to the buttock peripheral zone, stabilising pelvis support and preventing it from reaching the bottom zone.

THREE
PRE-ISCIAL RIDGE

Blocks the ischium, thus preventing forward sliding.



Paired Mattress:
Viscoflex Bariatric (P161MFPMHF120)
High-Very High Risk - SWL: 285kg

*Please note the information supplied here is a guide; if you would like more information or help with making the correct choice, please call our team today.

Product Information

Product Code	Dimensions	Paired Mattress	Safe Working Load
P361CAF56461HF	560(L)x460(W)x80(H) mm	Viscoflex Bariatric (P161MFPMHF120)	230kg/36st
P361CA61501HF	610(L)x500(W)x80(H) mm	Viscoflex Bariatric (P161MFPMHF120)	270kg/42st

GEL CUSHION



harvesthealthcare[®]
a prismhealthcare company

The Gel Cushion is made of high resilience, impermeable, viscoelastic polyurethane gel with highly elastic properties.

It is designed to enhance existing support surfaces.

KEY FEATURES & BENEFITS

- Thin, gel only
- Welded, water-resistant, four-way stretch cover
- Can be paired with our Community mattress for 24-hour pressure care
- Available in 2 different sizes
- Low to medium risk

3 year warranty



LOW MED HIGH V HIGH

PRESSURE RELIEF RISK

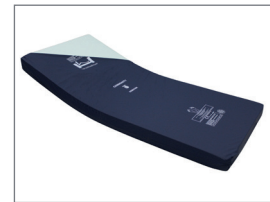

Paired Mattress:
Community (HSMCOM)
Medium Risk - SWL:159kg

Product Information

Product Code	Dimensions	Paired Mattress	Safe Working Load
P311C40401HF	400(L)x400(W)x25(H) mm	Community (HSMCOM)	120kg/18st
P311C45431HF	450(L)x430(W)x25(H) mm	Community (HSMCOM)	140kg/22st

ULTRA-THIN CUSHION



harvesthealthcare
a prismhealthcare company

The Ultra-Thin Cushion has been developed for use with a range of chairs. The viscoelastic foam offers excellent comfort, support and pressure distribution.

Available separately, each 35mm thick cushion provides enhanced pressure distribution to the current chair without compromising user posture. The thin nature of the cushion also ensures the patient remains safely in the chair, as the arms can still be a barrier.

This lightweight cushion is also available as a leg and lumbar system. It comes with a complete strap system to secure it to the chair. Comes with a water-resistant, vapour-permeable cover with an anti-slip base.

KEY FEATURES & BENEFITS

- Viscoelastic foam
- Zipped, vapour-permeable, water-resistant, four-way stretch cover
- Non-slip base
- It can be paired with our Reflect mattress for 24-hour pressure care
- Available in 2 different sizes
- A complete system consisting of seat, leg and lumbar pieces is also available (HFC143COM)
- High risk

3 year warranty



LOW MED HIGH V HIGH

PRESSURE RELIEF RISK



Paired Mattress:
Reflect 2 (HFR147)
High Risk - SWL: 247kg

Product Information

Product Code/Description	Dimensions	Paired Mattress	Safe Working Load
HFC143 - Seat Only	430(L)x430(W)x35(H) mm	Reflect 2 (HFR147)	152kg/23st
HFC143.20 - Seat Only (Larger)	508(L)x508(W)x35(H) mm	Reflect 2 (HFR147)	152kg/23st
HFC143COM (Seat, Leg and Lumbar Pieces)		Reflect 2 (HFR147)	152kg/23st

ACTIVE SEAT CUSHION



A one-piece alternating cushion that provides maximum patient comfort whilst achieving optimum pressure relief whilst seated.

Especially beneficial to patients who can no longer sleep in a hospital-type bed.

The cushion has 6 alternating cells.

KEY FEATURES & BENEFITS

- 6 alternating cells
- Zipped, water-resistant, four-way stretch cover
- Non-slip base
- It can be paired with our Hampton mattress for 24-hour pressure care
- Compatible with our Harvest 1 (analogue) and Harvest 2 (digital) pumps
- Very high risk

3 year warranty

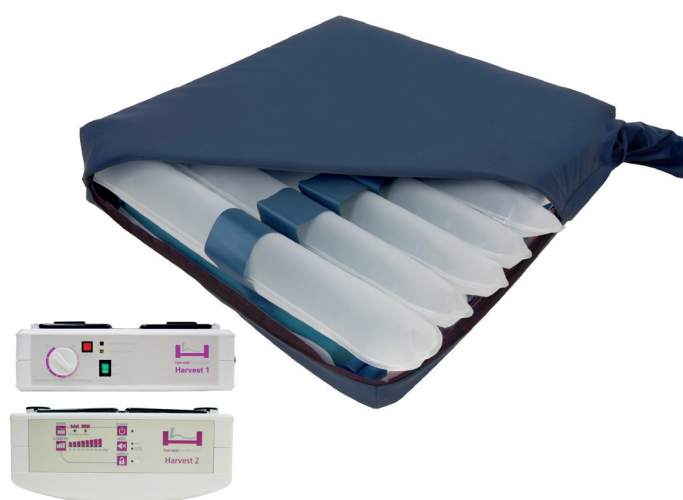

LOW MED HIGH V HIGH

PRESSURE RELIEF RISK



Paired Mattress:
Hampton (HAMHAMP001)
Very High Risk
SWL: HAMHAMP001.P1: 158kg
HAMHAMP001.P2: 184kg

Product Information

Product Code	Dimensions	Paired Mattress	Safe Working Load
HH20.P1	400(L)x430(W)x90(H) mm	Hampton (HAMHAMP001.P1)	158kg/25st
HH20.P2	400(L)x430(W)x90(H) mm	Hampton (HAMHAMP001.P2)	184kg/29st

BLENHEIM ACTIVE CUSHION



A one-piece alternating cushion that provides maximum patient comfort whilst achieving optimum pressure relief whilst seated.

Especially beneficial to patients who can no longer sleep in a hospital-type bed.

The Blenheim Active cushion has 9 alternating cells.

KEY FEATURES & BENEFITS

- 9 alternating cells
- Welded, water-resistant, four-way stretch cover
- Non-slip base
- It can be paired with our Balmoral mattress for 24-hour pressure care
- Compatible with our Harvest 2 (digital) pump
- Very high risk

3 year warranty



LOW MED HIGH V HIGH

PRESSURE RELIEF RISK



Paired Mattress:
Balmoral (HAMBALM001)
Very High Risk
SWL: HAMBALM001.P2: 184kg

Product Information

Product Code	Dimensions	Paired Mattress	Safe Working Load
HACBLEN001.P2	460(L)x460(W)x60(H) mm	Balmoral (HAMBALM001.P1)	152kg / 24st

3. POSITIONING AIDS

The Heel Pads and Positioning Aids from Harvest Healthcare feature high-quality, ergonomically designed aids which support and comfort patients. For best use when in beds and chairs, the positioning aids protect the relevant parts of the body from pressure damage and help to prevent skin damage at vulnerable locations.

INTEGRAL HEEL SUPPORT



harvesthealthcare[®]
a prismhealthcare company

The Integral Heel Support is made of viscoelastic foam with a memory effect. The heel is cushioned by the moulded high-density memory foam, which is shaped to protect wear on the achilles tendon and heel and direct pressure towards lower-risk areas. The heel support is particularly well suited to patients with normal or slightly limited mobility. It is also ideal for prevention in agitated patients or those subject to the constant movement of the lower limbs.

This comfort boot comes with a washable, breathable cover. It is fitted using soft Hook and Loop straps to tailor the perfect fit even to users with lower limb oedema.

KEY FEATURES & BENEFITS

- The heel area is hollowed out to provide protection against friction effects
- The sides of the forefoot sections are hollowed out to divert pressure towards the surrounding areas at lower risk
- Achilles tendon protected by the side supports that direct pressure towards areas at lower risk

MATERIAL

Visco foam; moulded and of very high density (80kg/m³, medical grade) memory foam.

Able to mould to the body to better reduce pressure on areas at high risk of ulcers.

1 year warranty



Product Information

Product Code	Description	Dimensions
P901T1HW	Integral Heel Support Viscoelastic Foam with Memory Foam	550(L) x 250 (W) x 75(H)mm

HEEL PAD



harvesthealthcare[®]
a prismhealthcare company

The Heel Pad is made of soft viscoelastic foam with a memory effect and firmer viscoelastic foam for support. The multi-bearing surface concept shifts pressure from high-risk to low-risk areas, and the end can be tucked under and secured if total pressure relief for the heels is required.

Available in single or double width, these clever positioning aids are excellent for protecting the heels and feet in those that are less mobile.

Well suited for people with moderate loss of mobility in lower limbs at medium to very high risk of pressure ulcers.

KEY FEATURES & BENEFITS

- Raised sides to avoid limbs slipping off
- Sloped to decrease pressure either partly or wholly on the heel
- Long to support the knee and prevent hyperextension
- Width enables freedom of movement
- Available in a half size to allow different positions for each leg

MATERIAL

Visco foam; moulded and of very high density (80kg/m³, medical grade) memory foam.

Able to mould to the body to better reduce pressures on areas at high risk of ulcers.

1 year warranty

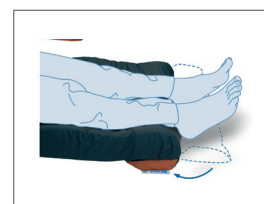

Product Information

Product Code	Description	Dimensions
P902T1HW	Heel Pad	730(L)x640(W)x105(H)mm
P904T1HW	Half Heel Pad	730(L)x320(W)x105(H)mm

HEEL SUPPORT BOOT



harvesthealthcare[®]
a prismhealthcare company

The Heel Support Boot is made of viscoelastic foam with a memory effect. Well suited for people with low mobility in lower limbs to assist in preventing and treating pressure ulcers. This zero-heel pressure boot comes with a washable, breathable cover.

The high-density visco foam is moulded for comfort and to prevent rotation and heel/tendon pressure, protecting all aspects of the foot.

KEY FEATURES & BENEFITS

- The heel area hollowed out for zero pressure
- The hollow area beneath the achilles tendon reduces pressure
- Curved outline to distribute pressure evenly
- Prevents equinus distortion and rotation

MATERIAL

Visco foam; moulded and of very high density (80kg/m³, medical grade) memory foam.

Able to mould to the body to better reduce pressures on areas at high risk of ulcers.

1 year warranty



Product Information

Product Code	Description	Dimensions
P903T1HW	Half Support Boot	635(L)x220(W)x310(H)mm

SEMI-FOWLER RETRACTION WEDGE



harvesthealthcare[®]
a prismhealthcare company

The Semi-Fowler Retraction Wedge is made of high-resiliency foam, which maintains positions over time for effective treatment.

This wedge is ideal for preventing and treating pressure ulcers on the sacrum and can be used with a range of heel-specific aids for more tailored care.

KEY FEATURES & BENEFITS

- The heel area hollowed out for zero pressure
- The hollow area beneath the achilles tendon reduces pressure
- Curved outline to distribute pressure evenly
- Prevents equinus distortion and rotation

MATERIAL

Visco foam; moulded and of very high density (80kg/m³, medical grade) memory foam.

Able to mould to the body to better reduce pressure on areas at high risk of ulcers.

1 year warranty

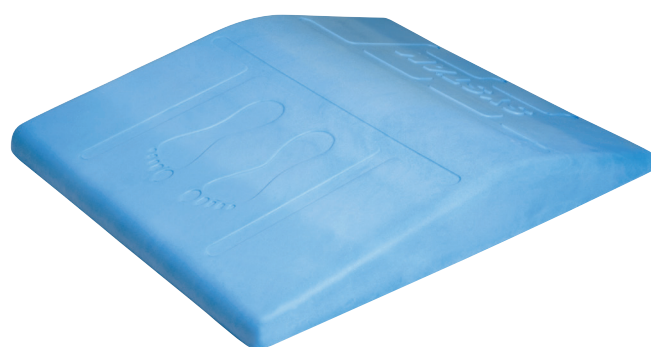

Product Information

Product Code	Description	Dimensions
P905T1HW	Semi-Fowler Retraction	620(L)x700(W)x75(H)mm

30° POSITIONING WEDGES



harvesthealthcare
a prismhealthcare company

The Positioning Wedge is made of memory foam with a stabilisation section of high-resiliency foam, designed to keep residents comfortable and stable in a 30-degree position while maintaining pressure relief. This comfortable positioning aid reduces the need for pillows or other bedding to support turns, gives carers peace of mind that their resident is in the optimum position, and helps the resident maintain position when unmonitored.

The stabilisation insert enables the 30° position to be maintained over time by acting as a support structure. Available full-sized or in half for the left or right side.

KEY FEATURES & BENEFITS

- Supports lower limb at the thigh level
- Hollowed out in sacrum area to relieve pressure and reduce painful contact areas
- Anatomical shape moulds to the body
- The reduced width of the wedge allows the patient to be centred on the bed, avoids accidental contact with side rails and stops it from becoming lodged between the side rails

MATERIAL

- Visco foam*
- High resiliency foam**

1 year warranty

Visco Foam: Moulded and of very high density (80kg/m³, medical grade) memory foam.

Able to mould to the body to better reduce pressures on areas at high risk of ulcers.*

High Resiliency Foam: Its mechanical properties (elasticity, flexibility) and high density (40kg/m³) enable positions to be maintained over time, allowing effective treatment.**



Product Information

Product Code	Description	Dimensions
P910L1HW	30 Degree Lateral Positioning Wedge with Cover	990(L)x550(W)x150(H)mm
P910LD1HW	30 Degree Lateral Positioning Half Wedge RHS Tilt	990(L)x280(W)x150(H)mm
P910LG1HW	30 Degree Lateral Positioning Half Wedge LHS Tilt	990(L)x280(W)x150(H)mm

POSITIONING WEDGES FOR UPPER LIMBS



harvesthealthcare[®]
a prismhealthcare company

The Wedge is made of viscoelastic foam with a memory effect. Designed to prevent and treat oedema. Available to support the whole arm or just the lower part.

Anatomically shaped to help comfort, it can be used on both the left and right side; extension of the elbow in a lying position avoids restricting vein perfusion in the forearm.

KEY FEATURES & BENEFITS

- Anatomically shaped to help comfort and maintain the position of the upper limbs over time
- Allows access for a drip to be used
- It can be used on both the left and right side
- Extension of the elbow in a lying position avoids restricting vein perfusion in the forearm

MATERIAL

Visco foam; moulded and of very high density (80kg/m³, medical grade) memory foam.

Able to mould to the body to better reduce pressure on areas at high risk of ulcers.

1 year warranty

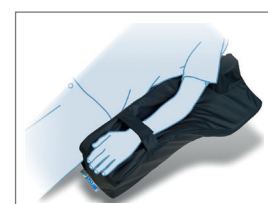

Product Information

Product Code	Description	Dimensions
P912L1HW	Positioning wedge for Upper Limbs	650(L)x370(W)x160(H)mm
P915L1HW	Positioning wedge for Upper Limbs	490(L)x190(W)x160(H)mm

ABDUCTION WEDGE



harvesthealthcare[®]
a prismhealthcare company

The Abduction Wedge is made of high-resiliency foam. Recommended for the prevention of postoperative dislocation and to help stabilise the legs in a position.

KEY FEATURES & BENEFITS

- Anatomically shaped to fit the natural angle between the lower limbs to ensure optimal distribution of pressure areas
- Fine curved tip to help carers position the wedge easily
- High enough for use in a chair and low enough to fit under a table

MATERIAL

High resiliency foam; its mechanical properties (elasticity, flexibility) and high density (40kg/m³) enable positions to be maintained over time, allowing effective treatment.

1 year warranty

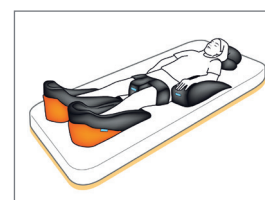
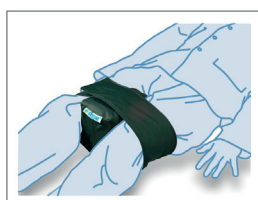
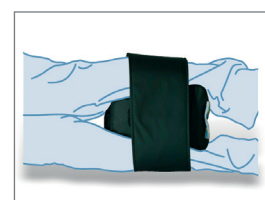
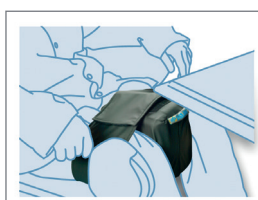

Product Information

Product Code	Description	Dimensions
P911L1HW	Abduction Wedge	240(L)x160(W)x180(H)mm

OCCIPITAL SYSTEM



harvesthealthcare[®]
a prismhealthcare company

The Occipital System provides prevention and positioning aid for the occipital area.

MATERIAL

Visco foam; moulded and of very high density (80kg/m³, medical grade) memory foam.

Able to mould to the body to better reduce pressures on areas at high risk of ulcers.

Viscoelastic foam with shape memory;

Defined body moulding and increased body surface area in contact with the foam

More effective distribution of pressure; reduction of transcutaneous pressure on high-risk zones, facilitated blood flow

Increased comfort and more effective maintenance of patient position

1 year warranty



Product Information

Product Code	Description	Dimensions
P913L1HW	Occipital Support	500(L)x430(W)x95(H)mm

UNIVERSAL CUSHION



harvesthealthcare[®]
a prismhealthcare company

The Universal Cushion provides postural aid and prevention for pressure ulcers. Helps to support the user, relieves pressure on the heels and protects the internal lateral knee areas and ankles. It can be used as postural aid in chairs and wheelchairs.

MATERIAL

Visco foam; moulded and of very high density (80kg/m³, medical grade) memory foam.

Able to mould to the body to better reduce pressures on areas at high risk of ulcers.

1 year warranty

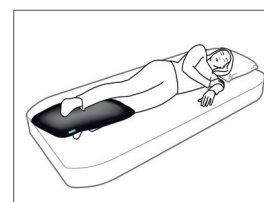
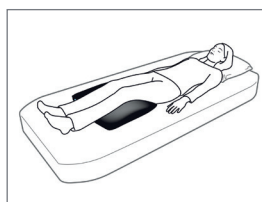
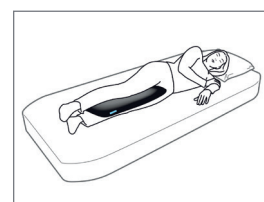
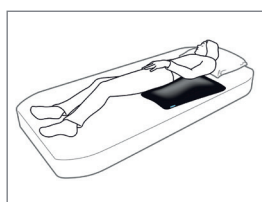

Product Information

Product Code	Description	Dimensions
P914L	Universal Cushion Large	600(L)x400(W)x130(H)mm

ABDUCTION BLOCK FOR KNEES CYLINDRICAL CUSHION



harvesthealthcare[®]
a prismhealthcare company

The **Abduction Block for Knees** is made of microbeads. The simultaneous use of the abduction block and cylindrical cushion achieves a comfortable Semi-Fowler position for the user. It also supports the dorsal position by firmly holding the pelvis and abducted areas in place thanks to the semi-circle cushion. Provides inner protection for the inner sides of the knees.

The **Cylindrical Cushion** is made of microbeads. It can be placed under the knees to maintain lower limbs in a Semi-Fowler position.

MATERIAL

Expanded polystyrene microbeads

Very light material: expanded polystyrene microbeads with small granulometry for enhanced comfort and adaptability of support to the patient's body.

Synthetic polyester fibre

Strong and resistant to stretching and shrinking. Retains air volume providing a soft sensation and increased comfort.

1 year warranty



Abduction Block for Knees



Cylindrical Cushion

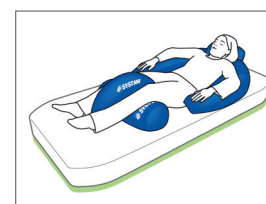
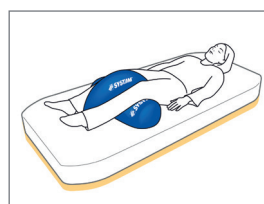

Product Information

Product Code	Description	Dimensions
P9703B1HW	Abduction Block for Knees	620(L)x320(W)
P9702B1HW	Cylinder Cushion	600(L)x200(Diameter)mm

UNIVERSAL CUSHION

RING CUSHION



harvesthealthcare[®]
a prismhealthcare company

The **Universal Cushion** is made of microbeads. It helps support the patient, relieves the pressure on the heels, protects the internal lateral knee areas and ankles and can be used as a pillow. It also comes in two sizes, small and standard.

The **Ring Cushion** is also made of microbeads. It comfortably supports the head in a sitting or semi-reclined position and has an easy-to-use, self-gripping strip.

MATERIAL

Expanded polystyrene microbeads

Very light material: expanded polystyrene microbeads with small granulometry for enhanced comfort and adaptability of support to the patient's body.

Synthetic polyester fibre

Strong and resistant to stretching and shrinking. Retains air volume providing a soft sensation and increased comfort.

1 year warranty



Universal Small and Standard Cushion



Ring Cushion



Product Information

Product Code	Description	Dimensions
P9700B1HW	Universal Cushion	350(L)x260(W)mm Small / 560(L)x400(W)mm Standard
P9704B1HW	Ring Cushion	500(Diameter)mm

HALF-MOON CUSHION

LATERAL POSITIONING CUSHION



harvesthealthcare[®]
a prismhealthcare company

The **Half-Moon Cushion** is made of microbeads. It holds the pelvis and upper body firmly in place when the user is in the Semi-Fowler or dorsal position and relieves pressure on elbows. It can be used on a wheelchair and is fitted with a strap for extra support to keep the head in position.

The **Lateral Positioning Cushion** is made of microbeads. Designed with an integrated pillow for optimal comfort, it ensures comfortable positioning of the knees, pelvis and upper body when in the lateral position. It is compatible with all patient sizes.

MATERIAL

Expanded polystyrene microbeads

Very light material: expanded polystyrene microbeads with small granulometry for enhanced comfort and adaptability of support to the patient's body.

Synthetic polyester fibre

Strong and resistant to stretching and shrinking. Retains air volume providing a soft sensation and increased comfort.

Both of them use an Easy Shape system to maintain a position adapted to the patient's body, thereby increasing comfort. By pulling on the straps, the curvature of the cushion increases and the shape is maintained by tying the straps.

1 year warranty



Half-Moon Cushion



Lateral Positioning Cushion

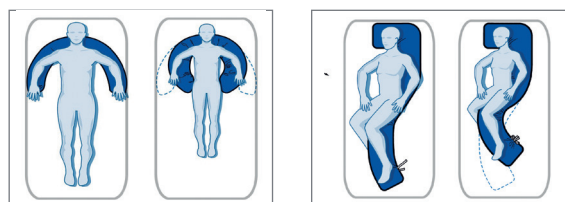

Product Information

Product Code	Description	Dimensions
P9705B1HW	Half-Moon Cushion	1350(L)x850(W)mm
P9707B1HW	Lateral Positioning Cushion	1800(L)x540(W)mm

CROSS PAD WEDGE WITH FRONT/BACK SLOPE



harvesthealthcare
a prismhealthcare company

The **Cross Pad** is made of microbeads. It enables hip and knee positioning and complete pressure relief of the heels. It has an adjustable strap to fix to the mattress.

The **Wedge with Front/Back Slope** enables the positioning of upper or lower limbs. The front/back slope relieves the heel or hand pressure points.

MATERIAL

Expanded polystyrene microbeads

Very light material: expanded polystyrene microbeads with small granulometry for enhanced comfort and adaptability of support to the patient's body.

Synthetic polyester fibre

Strong and resistant to stretching and shrinking. Retains air volume providing a soft sensation and increased comfort.

1 year warranty



Cross Pad



Wedge with Front/Back Slope

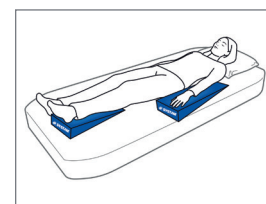
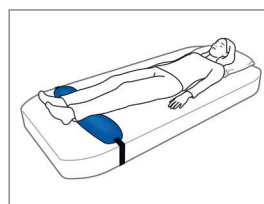

Product Information

Product Code	Description	Dimensions
P9709B1HW	Cross Pad	850(L)x250(W)x150(H)mm
P9712B1HW	Wedge with Front/Back Slope	460(L)x300(W)x150(H)mm

HIP ABDUCTION WEDGE DELTA CUSHION



harvesthealthcare[®]
a prismhealthcare company

The **Hip Abduction Wedge** enables hip abduction and the reduction of shear and friction forces on the lower limbs.

The **Delta Cushion** is a positioning cushion for the Semi-Fowler position.

MATERIAL

Expanded polystyrene microbeads

Very light material: expanded polystyrene microbeads with small granulometry for enhanced comfort and adaptability of support to the patient's body.

Synthetic polyester fibre

Strong and resistant to stretching and shrinking. Retains air volume providing a soft sensation and increased comfort.

1 year warranty



Hip Abduction Wedge



Delta Cushion

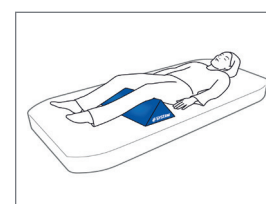
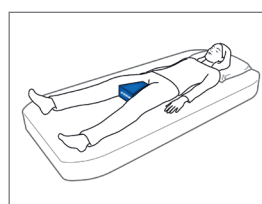

Product Information

Product Code	Description	Dimensions
P9711B1HW	Hip Abduction Wedge	300(L)x100-300(W)x150(H)mm
P9710B1HW	Delta Cushion	600(L)x400(W)x300(H)mm

4. FALL REDUCTION

The prevention and management of falls are essential in maintaining a patient's quality of life in a care home environment. Harvest Healthcare produce various products to assist in the likelihood of falls and sound an alert on patient movement. Our advanced alert system can be used in conjunction with an existing nurse call system and integrated into the framework of our Woburn bed range.

Please see our fall reduction flowchart guidance if you need clarification on which nurse call system suits your needs (page 92).

FALL REDUCTION



harvesthealthcare[®]
a prismhealthcare company

Harvest Healthcare alarm systems are available for seating and mattresses and can be connected to your current nurse call system. Be alerted immediately, or with a time delay, whenever one of your residents leaves their bed or chair.

Adjustable volume, optional alarm tones and a silent mode function when connected to your nurse call system all mean you can set up your system to work best.

The alarm systems are supplied with a charger as standard but can also be battery-operated (batteries not included).

KEY FEATURES & BENEFITS

- Compact
- Easily connected
- It can be used with an existing nurse call system
- Adjustable volume and silent mode
- Delayed alarm mode
- It can be battery operated



Nurse Call Floor Pressure Pad

Seat Pressure Pad

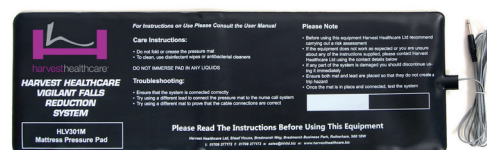

Bed Alarm System

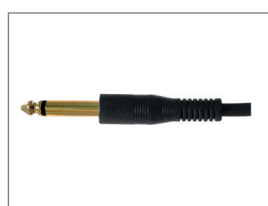

Mono Lead
HJM308



*Mono to Mono Lead
HJM309



**Y connector
HLV006

*Mono to Mono Lead, to be used in conjunction with seat pressure pad, mattress pressure pad and control box
** Y connector, to be used if the floor pad, mattress pad and seat pads are to be used together with 1 Nurse Call adapter in the room

Product Information

Product Code	Description
HJM301	Nurse Call Floor Pressure Pad
HJM302	Sensor Mat Carpet Cover (750 x 1000mm) (for the above floor pressure pad)
HJR075	Alarm System Control Box (to be used with the below mattress & seat pressure pads)
HLV301M	Alarm System Mattress Pressure Pad
HLV301S	Alarm System Seat Pressure Pad
HJM330.M	Nurse Call Handset with Mono Jack Plug (1.8m lead)
HJM330.S	Nurse Call Handset with Stereo Jack Plug (1.8m lead)

FALL REDUCTION FLOW CHART

Please see our fall reduction flowchart guidance if you're unsure which nurse call system suits your needs.

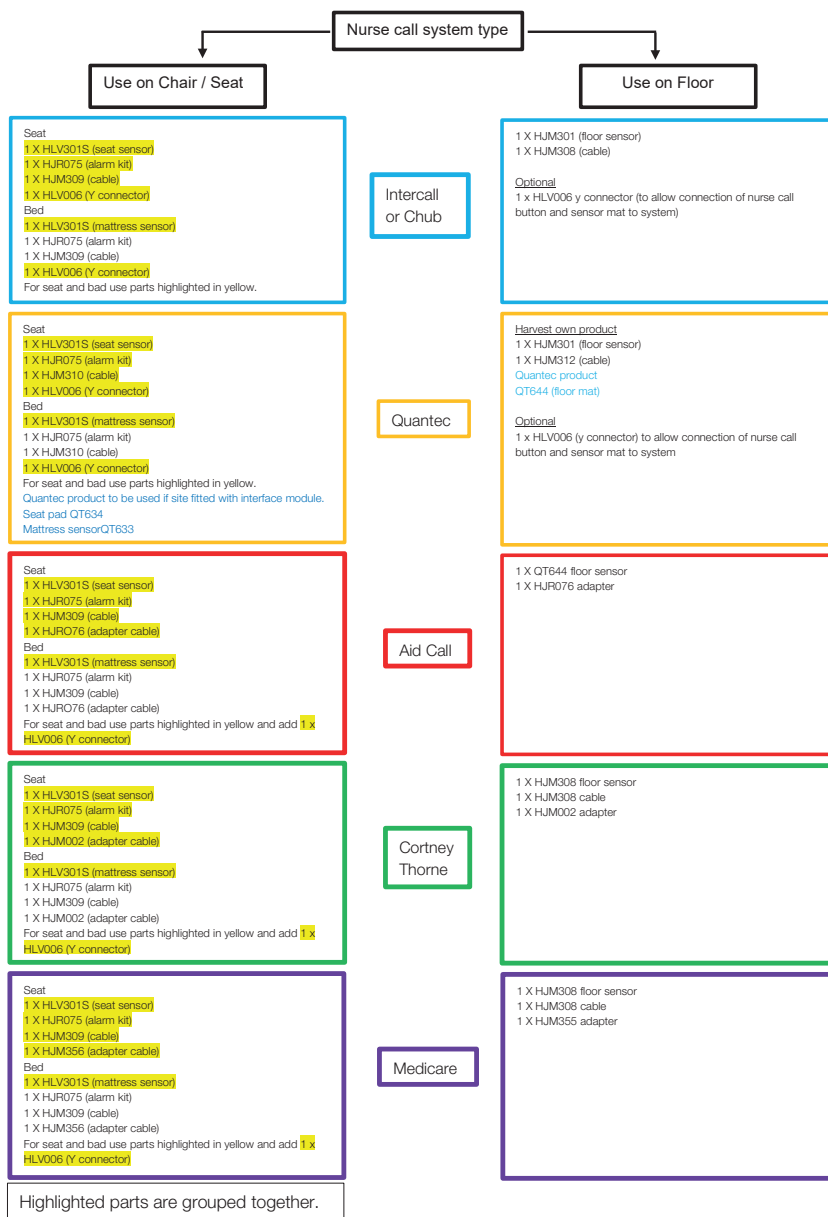

To find out more information about the different nurse call system connections, please visit our website:

<https://harvesthealthcare.co.uk/product-category/fall-reduction/>

If your nurse call system is not listed above or if there is anything you're unsure about, please get in touch with us at 01709 377172

Product Information

Product Code	Description
HJM002	Adapter Cable
HJM305	Infrared Bedside Motion Detector
HJM115	1/4" Mono Plug to Two Mono 1/4" Sockets Adapter
HJM310	Nurse Call Connection Lead 3m (Mono to Stereo 6.3mm Plug)
HJM312	Mat Lead 3m (6.3 Male Stereo to 3.5 Mono Male)

FALL REDUCTION



harvesthealthcare®
a prismhealthcare company

The Guardian is a modern wireless fall protection solution. Its fundamental purpose is to act as a pressure-sensitive warning system to alert nurses and carers to unexpected and potentially dangerous movements from users.

Triggered by a release or applied pressure to a surface, the Guardian can be configured to suit an extensive range of situations and requirements.

The package includes 1 Receiver, 1 transmitter and a power supply. The Guardian can also be used with Harvest wired sensor mats HLV301S and HLV301M. Additional components can be purchased separately.

KEY FEATURES & BENEFITS

- Safe and versatile wireless system
- Compatible with any nurse call system*
- Simple to set up and use
- 6 months plus battery life
- Pair up to 8 transmitters
- It can be paired with a variety of different pressure mats to suit various different situations
- Features adjustable alarm times to prevent accidental triggers



Guardian Receiver

Guardian Transmitters

*Different connections are required for different nurse call systems, please ask for more information.

Product Information

Product Code	Description
HJR079	Power Supply
HJM340	Receiver
HJM341	Transmitter
HJM343S	Seat Mat with Pocket
HJM343M	Mattress Mat with Pocket
HJM301	Floor Mat
HJM342	Adapter Cable to use HJM301
HJR078	Adapter Cable to use HLV301S and HLV301M

5. MOVING AND HANDLING

Prism Healthcare offers a comprehensive range of moving and handling equipment, including ceiling track and mobile hoists, stand aids, free-standing gantry systems, slings, belts and bed management systems. These are designed to support single-handed care, promoting mobility and allowing daily handling routines to be carried out safely, effectively and comfortably. They are suited to a wide range of care settings and provide a safe, practical solution for moving people in a dignified manner.

In this section you will find the following:

Stand Aids, Hoists and Transfer Aids

Ceiling Track Hoists

Slings

Bed Management Systems

Wheelchairs

MACKWORTH RAISER

mackworth

prismmedicaluk
a prismhealthcare company

Prism Medical UK's Mackworth Raiser is designed with the comfort, safety and ergonomics of both caregiver and patient in mind.

Designed for patients who have some capacity to pull themselves up but need a helping hand, the Mackworth Raiser requires patients to use their own strength and muscles, helping them to stay active.

The Mackworth Raiser is available with a single or dual knee pad.

KEY FEATURES & BENEFITS

- Assists a user with sit-to-stand transfers
- Lightweight and easy to manoeuvre
- Padded leg support for added comfort
- Multiple grip options for both user and carer
- Freeway Raiser Strap available to enable a carer to assist a user to their feet
- Compatible with Freeway safety and ladder belts
- Independent locking rear brakes
- 360° turning radius

5 year warranty



160kg/25st
max user weight



2002ACCRAISLAD	Freeway Ladder Belt
2002ACCRAISBELTS	Freeway Safety Belt - Small
2002ACCRAISBELTM	Freeway Safety Belt - Medium
2002ACCRAISBELTL	Freeway Safety Belt - Large



Freeway Safety Belt



Freeway Ladder Belt
590(W) x 120(D)mm

Product Information

Product Code	Description
1301TA-MWRAIS-1	Mackworth Raiser (Single Knee Pad)
1301TA-MWRAIS-2	Mackworth Raiser (Dual Knee Pad)

FREEWAY TRANSFER AID

freeway

prismmedicaluk
a prismhealthcare company

Simple and intuitive to use, the Freeway TA180 Transfer Aid is an attractive, quick and universal resident transport solution. Using the Freeway TA180 allows resident or patient transfers with minimal handling and more efficiency than other transfer options. The Freeway TA180 Transfer Aid supports residents to move comfortably from seated to standing position and promotes early mobilisation.

KEY FEATURES & BENEFITS

- Provides easy and more efficient transportation to the bathroom and toilet
- Offers a suitable alternative to a wheelchair
- Allows for better eye contact between the user and carer
- Padded knee support for extra comfort
- Manual leg open and closing
- Compatible with the Mackworth back support belt

5 year warranty



185kg/29st
max user weight



1201TAB550C	Back Support Belt S
1201TAB540C	Back Support Belt M
1201TAB530C	Back Support Belt L
1201TAB520C	Back Support Belt XL

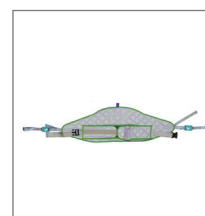

Back Support Belt



Product Information

Product Code	Length	Width	External Width (Legs Open)	Turning Radius
1301TA-FWTA180	950mm	680mm	1048mm	1010mm

FREEWAY STAND AID

freeway

prismmedicaluk
a prismhealthcare company

The Freeway SA180C supports the user when rising, using their own strength, to a standing position and during transfers.

The Freeway SA180C has been developed for patients with impaired balance and strength in their legs. The user must have some strength in the arms and be able to bear weight to actively participate in the transfer.

KEY FEATURES & BENEFITS

- Small and convenient
- Stimulates natural movement pattern
- Adjustable seat cushions that can be angled
- Adjustable lower leg support/knee-brace
- Adjustable base width

5 year warranty



180kg/28st
max user weight



Recommended for use with the SA180C
Knee Pad Strap: 119114

OPTIONAL EXTRAS:

- Charging Lead: 510092
- Snap Lead: 510091
- Battery Pack: 510005
- Handset: 123100

FREEWAY THORACIC SLINGS:

- Small: 12018Y0500
- Medium: 12018Y0400
- Large: 12018Y0300
- Extra large: 12018Y0200

Product Information

Product Code	Length	Width	Height
1301SA-SA180C	881.5mm	541mm	1428mm/1570mm

MACKWORTH STAND AIDS

mackworth mackworth
essentials

prismmedicaluk
a prismhealthcare company

The Mackworth Stand Aids have impressive ergonomic features to provide a safe and dignified lift.

They are uniquely designed to provide three functions; as a transfer hoist, sit-to-stand hoist and aid to rehabilitation by assisted standing.

Suitable for transferring patients into a wheelchair, onto toileting facilities, onto a bed, or for many other assisted transfers, the Mackworth Stand Aids are also excellent for standing exercises and promoting mobility.

The Mackworth SA180 (pictured) also features powered leg opening and closing.

KEY FEATURES & BENEFITS

- Ability to lift a wide range of people from 4ft – 6ft 5"
- Compact and easily manoeuvred
- Profiled push handles designed in conjunction with the REBA assessment tool allow for safe moving and positioning
- The powered leg opening on the Mackworth SA180, allows for a stable and safer lift without restricting access around chairs and beds
- Front and rear castors for maximum control and positioning on all floor surfaces
- A multi-directional knee pad allows for individual adjustment to provide full support
- The rear foot bar helps to manoeuvre the stand aid over uneven floor surfaces and door threshold

5 year warranty



180kg/28st
max user weight



Recommended for use with the Mackworth Maple slings range (please see p1) or Dual Access Poly:

- Small: 12018B0500
- Medium: 12018B0400
- Large: 12018B0300

OPTIONAL EXTRAS:

- Charging Lead: 510092
- Snap Lead: 510091
- Battery Pack: 510005
- Handset SA180E: 123103
- Handset SA180: 123105

Product Information

Product Code	Length	Height (Lowest/Highest)	Leg Inside Width (Closed/Spread)	Lifting Range
1301SA-ESS180 (Mackworth Essentials SA180E)	1190mm	1145mm/1685mm	540mm/1100mm	790-1670mm
1301SA-SA180 (Mackworth SA180)	1190mm	1145/1685mm	540mm/1100mm	790-1670mm

ASCENT PRO 200 PREMIUM STAND AID



With a sleek, ergonomic design, the Ascent Pro 200 provides ideal assistance for transfers while maintaining a home-from-home aesthetic.

Suitable for transferring patients into a wheelchair, onto toileting facilities, onto a bed, or for many other assisted transfers, the Ascent Pro 200 is also excellent for standing exercises and promoting mobility.

KEY FEATURES & BENEFITS

- Premium, sleek, aesthetic design
- Battery-operated height and leg adjustment
- Soft stop/start motion
- Handset operation with battery-level display
- LCD display for service notifications, actuator cycles and overloads
- Ergonomic handles
- Manual emergency lowering system
- Flexible extra soft knee supports with safety straps
- Removable non-slip footplate
- Enclosed castors keep out dirt and are easy to maintain

5 year warranty



200kg/31.5st
max user weight



OPTIONAL EXTRAS:

- Spare Battery: [ELE053A](#)
- Jumbo Charger Complete with Wall Mount Bracket & Lead: [ELE022](#)

Product Information

Product Code	Length	External Width (Closed/Spread)	Adjustable Height
HLA006	1027mm	700mm/1044mm	1168mm-1781mm

MACKWORTH HOISTS

mackworth mackworth
essentials

prismmedicaluk
a prismhealthcare company

The Mackworth Essentials 180 (pictured) and Mackworth M180 Hoists benefit from rigorous ergonomic design procedures and quality checks. They have been constructed from high-quality powder-coated steel that will provide years of reliable service. The hoists boast an impressive 180kg lifting capacity, powered leg-opening and market-leading Linak® actuators and motors.

Fixed and Folding options are available for the Mackworth M180.

KEY FEATURES & BENEFITS

- Cost-effective solution without compromising on quality
- Robust powder-coated steel frame
- Linak control system
- Electric leg opening on the Mackworth Essentials 180
- Red emergency lowering screw
- Easy to position with 4 large swivel castors and an ergonomic handle
- Tool-free assembly
- Single person installation

5 year warranty



180kg/28st
max user weight



OPTIONAL EXTRAS:

- Charging Lead: 510092
- Snap Lead: 510091
- Battery Pack: 510005
- Handset M180: 123101
- Handset Essentials 180: 123104



M180 Folding

Product Information

Product Code	Length	Height (Highest/Lowest)	Leg Inside Width (Closed/Open)	Lifting Range
1301MH-ESS180 (Mackworth Essentials 180)	1235mm	2010mm/1340mm	500mm/1100mm	1755mm
1301MH-M180FIXED (Mackworth M180 Fixed)	1310mm	1940mm/1340mm	510mm/1030mm	220-1660mm
1301MH-M180FOLD (Mackworth M180 Folding)	1310mm	1940mm/1340mm	510mm/1030mm	220-1660mm

FREEWAY HOIST AND PRISM BARIATRIC MOBILE HOIST

freeway prism

prismmedicaluk
a prismhealthcare company

The Freeway M205 and Prism A320-B Bariatric (pictured) Mobile Hoists provide beautifully designed, premium solutions for labour-intensive patient transfers, allowing for powered, single-carer use. The powered dynamic positioning system (PDPS) provides precise and stable positioning without manual intervention.

The height, leg-spreader and carrier frame are all electronically controlled, and the anti-rotation mechanism prevents unintentional rotational movement during lifting and transferring. The carrier frame can be lowered to the floor to pick up patients from the ground. Suited to a wide range of care environments.

KEY FEATURES & BENEFITS

- Aesthetic, compact design
- Emergency stop and emergency lowering
- Carrier frame and lifting column are made of aluminium (A320-B) and steel (M205)
- Enclosed lockable double castors
- Electrically adjustable height, cradle and spreadable carrier frame
- Anti-rotation mechanism

M205

5 year warranty



205kg/32st (M205)
max user weight

A320-B

5 year warranty



320kg/50st (A320-B)
max user weight



OPTIONAL EXTRAS:

- Charging Lead: 510092
- Snap Lead: 510091
- Battery Pack: 510005
- Handset: 123102

Product Information

Product Code	Length	Height (Highest/Lowest)	Leg Inside Width (Closed/Open)	Lifting Range
1301MH-FW-M205 (Freeway M205)	1235mm	2010mm/1340mm	500mm/1100mm	380-1755mm
1301MH-PUA-320B (Prism A320-B Bariatric Mobile Hoist)	1500mm	2160mm/1460mm	640mm/1066mm	640-1940mm

OLYMPIC EXTRA 230 PLUS SIZE HOIST



harvesthealthcare
a prismhealthcare company

The Olympic Extra 230 is a sling hoist specially made for lifting, moving and transferring plus-size patients. Due to the unique construction and the steel components, the Olympic Extra is extra light and easy to move. Still, it offers the required stability for the care of plus size patients.

We provide compatible slings for our hoists.

KEY FEATURES & BENEFITS

- Aesthetic design
- Universal use, also appropriate for bathing
- Extra light and easy to manoeuvre
- An electrical positioning system (EPS) places the patient precisely without additional force
- Electrically adjustable height, cradle and spreadable carrier frame for easier patient transfer
- Lifts from the floor
- No rotational movements during lifting and transferring due to the anti-rotation mechanism
- Hand control with battery charge status display
- In-built electronic scales (optional extra)
- Wall charging station (optional extra)

5 year warranty



230kg/36st
max user weight



OPTIONAL EXTRAS:

- Jumbo Charger Complete with Wall Mount Bracket & Lead: [ELE022](#)
- Jumbo Battery Pack: [ELE053A](#)



Pivot frame
To be used with clip slings



2 point yoke frame
To be used with loop slings

Product Information

Product Code	Length	External Width (Legs Open)	Min Height / Max Height
HLA007	1400mm	1240mm	1340mm / 2170mm

PRISM FREE STANDING GANTRY AND PRISM PORTABLE TRACK HOIST

prism

prismmedicaluk
a prismhealthcare company

The fully portable Free Standing Gantry can easily be moved to any location and assembled by one person in minutes.

The Prism CP200 Portable Ceiling Track Hoist offers exceptional versatility as it can be used with either a fixed ceiling track or gantry systems.

KEY FEATURES & BENEFITS

FSG200

- Safe working load of 200kg (31.5 stone)
- No room modifications are required for permanent or temporary applications
- Secure and sturdy
- Easy to assemble – no tools required
- Height adjustable to 1950mm
- It can be used with the Freeway CP200 hoist

CP200

- Safe Working Load 200kg (31.5 stone)
- Option to use as a fixed ceiling track hoist or portable hoist
- Small compact design
- Works in conjunction with any Prism Gantry System
- Easy to operate the electric handset
- Quiet operation with 'soft start/stop'
- 360° quick-release attachment for ease of attaching/detaching to/from the track
- Integrated carry bar and hook QRS (Quick Release System) latches

5 year warranty



200kg/31.5st
max user weight



Product Information

Product Code	Description
1102PH-FSG200	Prism FSG-200
1001CP200	Prism CP200 Portable Hoist
1001CP200/FSG	Package for FSG200 & CP200

FREEWAY TX ADVANCED FIXED TRACK HOIST



This is our most comprehensive ceiling track hoist, featuring superior lift tape, improved design and TUV certification.

The Freeway TX advanced is available as a manual or powered traverse and can come with one of the following additional options:

- Quick-release trolley (QRT)
- Constant charge
- Powered h-system
- Powered turntable

KEY FEATURES & BENEFITS

- Safe Working Load 272kg (42 stone)
- The 2m lifting range makes it suitable for most users
- Discreet design built to last
- Easy to use pneumatic handset with the option to move the hoist forwards/backwards where the powered traverse option has been installed
- LCD displays battery level and service information
- Powered emergency lowering, manual lowering and emergency stop included as standard
- Suitable for a range of different fixed-track systems
- The quick-release carry bar makes it easy to change or attach the option QRS scale unit
- The optional extras allow for user customisation
- High quality is verified by TUV certification

5 year warranty



272kg/42st
max user weight



Product Information

Product Code*	Description
1001TXADV122602	TX132 powered drive for Prism track (130kg safe working load)
1001TXADV122607	TX202 powered drive for Prism track (200kg safe working load)
1001TXADV122612	TX272 powered drive for Prism track (272kg safe working load)

* There are various options to suit different tracks and user needs. Please speak with your local representative to find out which is right for you.

FREEWAY TRANSACTIVE XTRA FIXED TRACK HOIST

freeway

prismmedicaluk
a prismhealthcare company

The Freeway Transactive Xtra is a lifting aid that allows people to move with limited mobility. It has a discreet design yet still boasts an impressive lifting height of 2m.

With a range of track layouts available, advanced safety features and valuable diagnostic tools, the Transactive Xtra can significantly improve the quality of life for its users.

KEY FEATURES & BENEFITS

- Safe Working Load 270kg (42 stone)
- The 2m lifting range makes it suitable for most users
- Powered and manual traverse options are available
- Discreet design built to last
- Easy to use pneumatically controlled handset with the 2, 4 or 6 button operation
- Powered emergency lowering, manual lowering and raising facility, plus emergency stop included as standard
- Constant charge is available for Prism track

5 year warranty



270kg/42st
max user weight



Product Information

Product Code*	Description
1001TX270	Freeway Transactive Xtra Manual - 270kg
1001TX270D	Freeway Transactive Xtra Drive - 270kg

* There are various options to suit different tracks and user needs. Please speak with your local representative to find out which is right for you.

MACKWORTH TX FIXED TRACK HOIST

mackworth

prismmedicaluk
a prismhealthcare company

The Mackworth TX is a lifting aid that makes it possible to move people with limited mobility. It is TUV certified and designed to provide comfort and support to the client during the transfer.

The hoist features a low-profile design, manual travel, a superior battery and a lifting range of up to 2000mm. It can lift patients to 272kg and offer complete flexibility with a range of track layouts available.

KEY FEATURES & BENEFITS

- Safe Working Load 272kg (42 stone)
- The 2m lifting range makes it suitable for most users
- Discreet design built to last
- Easy to use pneumatic handset for raising/lowering the carry bar
- LCD displays battery level and service information
- Powered emergency lowering, manual lowering and emergency stop included as standard
- Suitable for a range of different fixed-track systems
- The quick-release carry bar makes it easy to change or attach the option QRS scale unit
- High quality is verified by TUV certification

5 year warranty



272kg/42st
max user weight



Product Information

Product Code*	Description
1001TX122500	Mackworth TX for Prism track (130kg safe working load)
1001TX122505	Mackworth TX for Prism track (200kg safe working load)
1001TX122510	Mackworth TX for Prism track (272kg safe working load)

* There are various options to suit different tracks and user needs. Please speak with your local representative to find out which is right for you.

MACKWORTH ESSENTIALS CT FIXED TRACK HOIST

mackworth
essentials

prismmedicaluk
a prismhealthcare company

The Mackworth Essentials CT Ceiling Track Hoist is a lifting aid that transfers clients safely.

The hoist features a wired electric handset and a lifting range of up to 2100mm.

KEY FEATURES & BENEFITS

- Safe Working Load 200kg (31 stone)
- The 2.1m lifting range makes it suitable for most users
- Discreet design built to last
- Wired electric handset with intuitive controls
- LED battery level and fault information
- In-track or handset charging available
- Powered emergency lowering and emergency stop included as standard
- Suitable for a range of different fixed-track systems
- The quick-release carry bar makes it easy to change or attach the option QRS scale unit

5 year warranty



200kg/31st
max user weight



Product Information

Product Code*	Description
1001CT108500	CT130 for Prism track with in-track charge and black carry bar (130kg safe working load)
1001CT108501	CT130 for Prism track with handset charge and black carry bar (130kg safe working load)
1001CT108510	CT200 for Prism track with in-track charge and black carry bar (200kg safe working load)

* There are various options to suit different tracks and user needs. Please speak with your local representative to find out which is right for you.

FREEWAY SCALES UNIT INCORPORATING QRS

freeway

prismmedicaluk
a prismhealthcare company

A dignified, accurate and convenient method of determining body mass by weighing an individual whilst situated in a sling and suspended by a hoist.

This product is compatible with any Prism Medical QRS product which contains a QRS hook.

KEY FEATURES & BENEFITS

- Fits inline between the hoist and the carry bar
- Load of 10 to 320kg (maximum functional load is limited by the hoist or sling, i.e. 180kg when used with the Mackworth M180 hoist).
- QRS (Quick Release System)
- 1 button operation
- Auto shut down after 60 seconds (programmable)
- 15mm LED screen
- Display resolution to 0.2kg
- Class III accuracy

5 year warranty



320kg/50st
max user weight

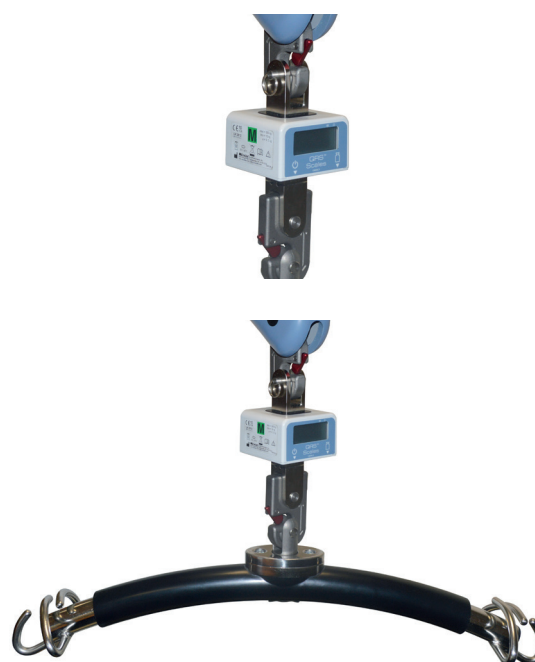

Product Information

Product Code	Description
1102QRSSCCASSY	QRS Scales and Case Assy

UNIVERSAL DELUXE SLING

care-ability

prismmedicaluk
a prismhealthcare company

This multi-purpose sling is designed to offer excellent support. It can be used for most patients, including bathing when using super soft material.

Available in polyester, which is versatile, breathable and durable.

Also available in super soft 3-dimensional fabric, which is breathable, very durable and provides excellent pressure distribution. The super soft fabric is also fast drying and therefore suitable for bathing.

KEY FEATURES & BENEFITS

- Can be applied and removed while seated in a chair
- Full padded support of the upper thigh reduces hip rotation and abduction
- Available in a range of sizes
- Available in Polyester and Super Soft material
- Pocket in the back of the sling to aid proper fitting
- Available with head support
- Also available with clip fastening
- Extra stitching to improve life and safe working load of the sling
- Information stitched into the label to protect when washing



300kg/47st (super soft)
max user weight



400kg/62st (Polyester)
max user weight

1 year warranty

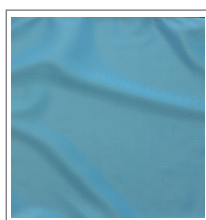

Available in
Polyester Fabric



Available in
Super Soft Fabric



Universal Deluxe
Loop Sling



Universal Deluxe
Clip Sling

Product Information

Product Code	Sizes	Width (cm)	Back Length (cm)
Please see pages 113 - 116	Small	81	136
	Medium	91	154
	Large	106	167
	X Large	111	170

IN-CHAIR HAMMOCK SLING

care-ability

prismmedicaluk
a prismhealthcare company

The In-Chair Hammock Sling is designed to support the back, neck and shoulders fully.

Available in polyester, which is versatile, breathable and durable.

Also available in super soft 3-dimensional fabric, which is breathable, very durable and provides excellent pressure distribution. The super soft fabric is also fast drying and therefore suitable for bathing.

KEY FEATURES & BENEFITS

- Hip Straps
- Pommel
- Pockets to tuck lifting straps in
- Available in a range of sizes
- Available in Polyester and Super Soft materials
- Also available with clip fastening
- Extra stitching to improve life and safe working load of the sling
- Information is stitched into the label to protect it when washing



300kg/47st (super soft)
max user weight



400kg/62st (Polyester)
max user weight

1 year warranty

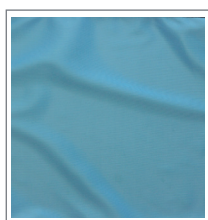

Available in
Polyester Fabric



Available in
Super Soft Fabric



In Chair Hammock
Loop Sling

Product Information

Product Code	Sizes	Width (cm)
Please see pages 113 - 116	Small	86
	Medium	96
	Large	116
	X Large	129

TOILET/DRESS SLING

care-ability

prismmedicaluk
a prismhealthcare company

The Toilet/Dress Sling has been designed to help facilitate the toileting process, with good access to remove clothing.

Available in polyester, which makes it versatile, breathable and durable.

KEY FEATURES & BENEFITS

- Easy to fit
- Fully padded
- Adjustable Hook and Loop body belt
- Wide legs for additional comfort
- Slide sheet material on legs to reduce friction and ease fitting
- Available in a range of sizes
- Also available with clip fastening
- Extra stitching to improve life and safe working load of the sling
- Information is stitched into the label to protect it when washing

1 year warranty



400kg/62st
max user weight

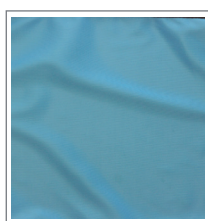

Available in
Polyester Fabric



Toilet/Dress
Sling

Product Information

Product Code	Sizes	Width (cm)	Back Length (cm)
Please see pages 113 - 116	Small	70	98
	Medium	82	119
	Large	101	126
	X Large	111	130

STAND AID SLING

care-ability

prismmedicaluk
a prismhealthcare company

The Stand Aid Sling works with a hoist to assist with standing. It can be used with Mackworth M180 Stand Aid.

Available in polyester, which makes it versatile, breathable and durable.

KEY FEATURES & BENEFITS

- Easy to fit
- Fully padded
- Adjustable Hook and Loop body belt
- Available in a range of sizes
- Also available with clip fastening
- Extra stitching to improve life and safe working load of the sling
- Information is stitched into the label to protect it when washing

1 year warranty



400kg/62st
max user weight

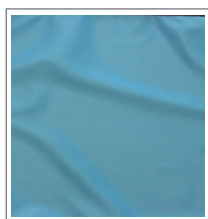

Available in
Polyester Fabric

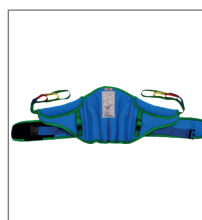

Stand Aid Loop Sling

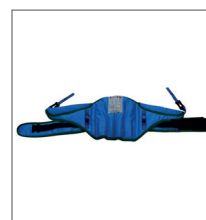

Stand Aid Clip Sling

Product Information

Product Code	Sizes	Width (cm)
Please see pages 113 - 116	Small	86
	Medium	92
	Large	98
	X Large	104

SLING CODES

care-ability

prismmedicaluk
a prismhealthcare company

Universal Deluxe Sling

Product Code	Description	Material	Size
1201CA400PS	Universal Deluxe Sling with Loop	Polyester	Small
1201CA400PM	Universal Deluxe Sling with Loop	Polyester	Medium
1201CA400PL	Universal Deluxe Sling with Loop	Polyester	Large
1201CA400PXL	Universal Deluxe Sling with Loop	Polyester	Extra Large
1201CA400SS	Universal Deluxe Sling with Loop	Super Soft	Small
1201CA400SM	Universal Deluxe Sling with Loop	Super Soft	Medium
1201CA400SL	Universal Deluxe Sling with Loop	Super Soft	Large
1201CA400SXL	Universal Deluxe Sling with Loop	Super Soft	Extra Large
1201CA400PSC	Universal Deluxe Sling with Clip	Polyester	Small
1201CA400PMC	Universal Deluxe Sling with Clip	Polyester	Medium
1201CA400PLC	Universal Deluxe Sling with Clip	Polyester	Large
1201CA400PXC	Universal Deluxe Sling with Clip	Polyester	Extra Large
1201CA400SSC	Universal Deluxe Sling with Clip	Super Soft	Small
1201CA400SMC	Universal Deluxe Sling with Clip	Super Soft	Medium
1201CA400SLC	Universal Deluxe Sling with Clip	Super Soft	Large
1201CA400SXC	Universal Deluxe Sling with Clip	Super Soft	Extra Large
1201CA701PS	Universal Deluxe Sling with Head Support & Loop	Polyester	Small
1201CA70PM	Universal Deluxe Sling with Head Support & Loop	Polyester	Medium
1201CA701PL	Universal Deluxe Sling with Head Support & Loop	Polyester	Large
1201CA701PXL	Universal Deluxe Sling with Head Support & Loop	Polyester	Extra Large
1201CA701SS	Universal Deluxe Sling with Head Support & Loop	Super Soft	Small
1201CA70SM	Universal Deluxe Sling with Head Support & Loop	Super Soft	Medium
1201CA701SL	Universal Deluxe Sling with Head Support & Loop	Super Soft	Large
1201CA701SXL	Universal Deluxe Sling with Head Support & Loop	Super Soft	Extra Large

SLING CODES

care-ability

prismmedicaluk
a prismhealthcare company

Universal Deluxe Sling

Product Code	Description	Material	Size
1201CA701PSC	Universal Deluxe Sling with Head Support & Clip	Polyester	Small
1201CA70PMC	Universal Deluxe Sling with Head Support & Clip	Polyester	Medium
1201CA701PLC	Universal Deluxe Sling with Head Support & Clip	Polyester	Large
1201CA701PXLC	Universal Deluxe Sling with Head Support & Clip	Polyester	Extra Large
1201CA701SSC	Universal Deluxe Sling with Head Support & Clip	Super Soft	Small
1201CA70SMC	Universal Deluxe Sling with Head Support & Clip	Super Soft	Medium
1201CA701SLC	Universal Deluxe Sling with Head Support & Clip	Super Soft	Large
1201CA701SXLC	Universal Deluxe Sling with Head Support & Clip	Super Soft	Extra Large

In-Chair Hammock Sling

Product Code	Description	Material	Size
1201CA720PS	In Chair Hammock Sling with Loop	Polyester	Small
1201CA720PM	In Chair Hammock Sling with Loop	Polyester	Medium
1201CA720PL	In Chair Hammock Sling with Loop	Polyester	Large
1201CA720PXL	In Chair Hammock Sling with Loop	Polyester	Extra Large
1201CA720SS	In Chair Hammock Sling with Loop	Super Soft	Small
1201CA720SM	In Chair Hammock Sling with Loop	Super Soft	Medium
1201CA720SL	In Chair Hammock Sling with Loop	Super Soft	Large
1201CA720SXL	In Chair Hammock Sling with Loop	Super Soft	Extra Large
1201CA720PSC	In Chair Hammock Sling with Clip	Polyester	Small
1201CA720PMC	In Chair Hammock Sling with Clip	Polyester	Medium
1201CA720PLC	In Chair Hammock Sling with Clip	Polyester	Large
1201CA720PXLC	In Chair Hammock Sling with Clip	Polyester	Extra Large
1201CA720SSC	In Chair Hammock Sling with Clip	Super Soft	Small
1201CA720SMC	In Chair Hammock Sling with Clip	Super Soft	Medium
1201CA720SLC	In Chair Hammock Sling with Clip	Super Soft	Large
1201CA720SXLC	In Chair Hammock Sling with Clip	Super Soft	Extra Large

SLING CODES

care-ability

prismmedicaluk
a prismhealthcare company

Toilet/Dress Sling

Product Code	Description	Material	Size
1201CA500PS	Toilet/Dress Sling with Loop	Polyester	Small
1201CA500PM	Toilet/Dress Sling with Loop	Polyester	Medium
1201CA500PL	Toilet/Dress Sling with Loop	Polyester	Large
1201CA500PXL	Toilet/Dress Sling with Loop	Polyester	Extra Large

Stand Aid Sling

Product Code	Description	Material	Size
1201CA800PS	Stand Aid Sling with Loop	Polyester	Small
1201CA800PM	Stand Aid Sling with Loop	Polyester	Medium
1201CA800PL	Stand Aid Sling with Loop	Polyester	Large
1201CA800PXL	Stand Aid Sling with Loop	Polyester	Extra Large
1201CA800PSC	Stand Aid Sling with Clip	Polyester	Small
1201CA800PMC	Stand Aid Sling with Clip	Polyester	Medium
1201CA800PLC	Stand Aid Sling with Clip	Polyester	Large
1201CA800PXC	Stand Aid Sling with Clip	Polyester	Extra Large

CARE-ABILITY SLING MEASURING GUIDE

care-ability

prismmedicaluk
a prismhealthcare company

Sling Sizing Guide

1. Measure the width of your resident between the outer midpoints of each upper arm as per the diagram (W).
2. In the table below, compare your measurement with the user 'Width range' for the selected sling type.
3. In the table below, compare your measurement with the user 'Back Length range' for the selected sling type. Please note that some ranges overlap; select the most appropriate size in these cases.
4. If these two measurements correlate, your resident fits a standard sling. If not, consider a bespoke sling or select the most appropriate standard sling after a risk assessment.

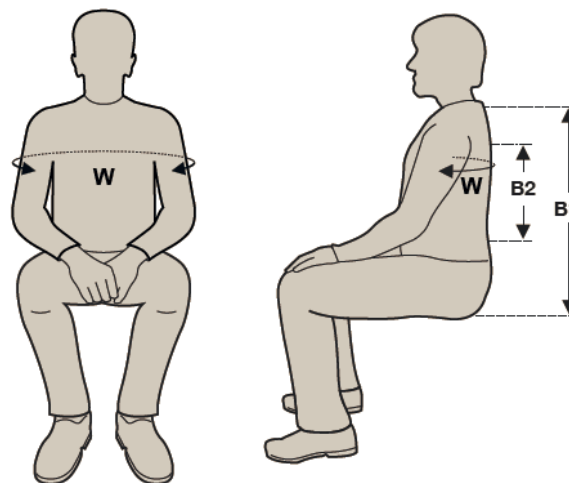

SLING COLOUR CHART

	Universal		Universal Deluxe		Classic Hammock	
	Width range (cm)	Back length range (cm) B1	Width range (cm)	Back length range (cm) B1	Width range (cm)	Back length range (cm) B2
XS	45-52	48-56	45-52	48-56	45-52	48-56
S	52-60	53-63	52-60	53-63	52-60	53-63
M	60-76	57-67	60-76	63-73	60-76	57-67
L	76-92	62-72	76-92	68-78	76-92	62-72
XL	92-100	65-75	92-100	68-78	92-100	65-75

SLING COLOUR CHART

	In Chair Hammock		Toilet with Head Support	
	Width range (cm)	Back length range (cm) B2	Width range (cm)	Back length range (cm) B2
XS	45-52	48-56	40-50	26-30
S	52-60	53-63	50-60	29-34
M	60-76	57-67	60-70	34-40
L	76-92	62-72	70-80	36-42
XL	92-100	65-75	80-90	38-44

All sling selections should be accompanied by a risk assessment by a trained person. People of atypical anatomy may not be suited to a standard sling.

FREEWAY FALLS RECOVERY SLING

freeway

prismmedicaluk
a prismhealthcare company

The Freeway Falls Recovery Sling allows carers to safely transfer someone who needs assistance immediately after a fall. It has a versatile, one-size-fits-all design suitable for adults and children.

The Freeway Falls Recovery Sling allows the fallen person to be rolled onto the sling whilst lying. Once moved onto the sling, the person can be easily slid to a more open area as required for the suitable positioning of a hoist. The person can then be hoisted off the floor safely into a chair or bed.

KEY FEATURES & BENEFITS

- Versatile design – suitable for adults and children
- Strong, yet built for comfort
- Low friction material for comfortable transfer and sliding of a person (the yellow side)
- Easy application and removal
- Integral space-saving storage and carry bag
- Machine washable



200kg/31st
max user weight



Product Information

Product Code	Description	Material	Size
12018E3-FRS	Falls Recovery Sling - Loop	Polyester /Slipfit	One Size
12018SL3C-FRS	Falls Recovery Sling - Clip	Polyester /Slipfit	One Size

FREEWAY FALLS RECOVERY SLING

freeway

prismmedicaluk
a prismhealthcare company



MACKWORTH OAK UNIVERSAL SLING

mackworth

prismmedicaluk
a prismhealthcare company

This multi-purpose sling is designed to offer excellent support. It can be used for most patients, including bathing, when using super soft material.

Available in various fabrics, including polyester, which is versatile, breathable and durable.

Also available in super soft 3-dimensional fabric, which is breathable, very durable and provides excellent pressure distribution. The super soft fabric is also fast drying and therefore suitable for bathing.

KEY FEATURES & BENEFITS

- Can be applied and removed while seated in a chair
- Height adjustable for multi-patient application
- Available in a range of sizes
- Available in Polyester, Parasilk, Quilted and Super Soft material
- Available with head support
- Clip and loop options are available
- Modesty loop to protect patient dignity
- Information stitched into the label to protect when washing

1 year warranty

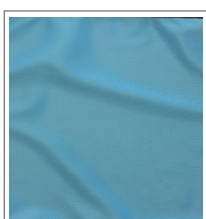

Available in
Polyester Fabric

Product Information

Product Code	Sizes	Width Range (mm)	Back Length Range (mm)
Please see pages 124 - 125	Small	547-636	475-555
	Medium	617-717	490-590
	Large	674-783	585-685
	X Large	712-828	610-710

MACKWORTH HAZEL CLASSIC UNIVERSAL SLING

mackworth

prismmedicaluk
a prismhealthcare company

This multi-purpose sling is designed to offer excellent support. It can be used for most patients, including bathing, when using super soft material.

Available in various fabrics, including polyester, which is versatile, breathable and durable.

Also available in super soft 3-dimensional fabric, which is breathable, very durable and provides excellent pressure distribution. The super soft fabric is also fast drying and therefore suitable for bathing.

KEY FEATURES & BENEFITS

- Can be applied and removed while seated in a chair
- Height adjustable for multi-patient application
- Dual-sided handles ease manoeuvrability
- Available in a range of sizes
- Available in Polyester, Parasilk, Quilted and Super Soft material
- Available with head support
- Modesty loop to protect patient dignity
- Information stitched into the label to protect when washing

1 year warranty

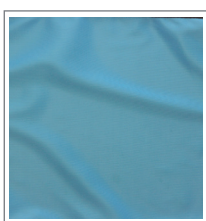

Available in
Polyester Fabric

Product Information

Product Code	Sizes	Width Range (mm)	Back Length Range (mm)
Please see pages 124 - 125	Small	547-636	475-555
	Medium	617-717	490-590
	Large	674-783	585-685
	X Large	712-828	610-710

MACKWORTH PINE HAMMOCK SLING

mackworth

prismmedicaluk
a prismhealthcare company

The Mackworth Pine Hammock Sling is designed to provide full support to the back, neck and shoulders, offering all-day comfort.

Available in various fabrics, including polyester, which is versatile, breathable and durable.

Also available in super soft 3-dimensional fabric, which is breathable, very durable and provides excellent pressure distribution. The super soft fabric is also fast drying and therefore suitable for bathing.

KEY FEATURES & BENEFITS

- Can be applied and removed while seated in a chair
- Height adjustable for multi-patient application
- Available in a range of sizes
- Available in Polyester, Parasilk, Quilted and Super Soft material
- Loop and clip options are available
- Available with head support
- Specialist design suitable for amputees
- Information stitched into the label to protect when washing

1 year warranty



**Super Soft fabric
is pressure
relieving and
breathable**

Product Information

Product Code	Sizes	Width Range (mm)	Back Length Range (mm)
Please see pages 124 - 125	Small	551-640	850-950
	Medium	604-702	950-1050
	Large	658-765	1020-1120
	X Large	693-806	1100-1200

MACKWORTH WILLOW LUXURY TOILET SLING

mackworth

prismmedicaluk
a prismhealthcare company

The Willow Toilet Sling has been designed to help facilitate the toileting process, with good access to remove clothing.

Available in polyester, which makes it versatile, breathable and durable.

KEY FEATURES & BENEFITS

- Easy to fit
- Under-arm padding
- The design allows for easy removal of clothing
- Adjustable body belt provides safety
- Available in a range of sizes
- Loop and clip options are available
- Available with head support
- Information stitched into the label to protect when washing

1 year warranty



Available in
Polyester Fabric

Product Information

Product Code	Sizes	Width Range (mm)	Back Length Range (mm)
Please see pages 124 - 125	Small	581-688	448-560
	Medium	662-784	448-560
	Large	709-840	488-610
	X Large	763-904	496-620

MACKWORTH MAPLE STAND AID BACK SUPPORT

mackworth

prismmedicaluk
a prismhealthcare company

The Maple padded back support belt provides comfort and stability when the patient needs it. The back support has a wider cut for use with a stand aid hoist, and the polycarbonate stays provide additional spinal support.

Available in quilted polyester, which enhances patient comfort.

KEY FEATURES & BENEFITS

- Easy to fit
- Fully padded
- Available in a range of sizes
- Loop and clip options are available

1 year warranty



Available in
Polyester Fabric

Product Information

Product Code	Sizes
Please see pages 124 - 125	Small Medium Large X Large

SLING CODES

mackworth

prismmedicaluk
a prismhealthcare company

Mackworth Oak Universal Sling

Product Code	Description	Material	Size
1201OK7500	Mackworth Oak Universal Sling with Loop	Polyester	Small
1201OK7400	Mackworth Oak Universal Sling with Loop	Polyester	Medium
1201OK7300	Mackworth Oak Universal Sling with Loop	Polyester	Large
1201OK7200	Mackworth Oak Universal Sling with Loop	Polyester	Extra Large
1201OK750C	Mackworth Oak Universal Sling with Clip	Polyester	Small
1201OK740C	Mackworth Oak Universal Sling with Clip	Polyester	Medium
1201OK730C	Mackworth Oak Universal Sling with Clip	Polyester	Large
1201OK720C	Mackworth Oak Universal Sling with Clip	Polyester	Extra Large

Mackworth Hazel Classic Universal Sling

Product Code	Description	Material	Size
1201HZ7500	Mackworth Hazel Classic Universal Sling with Loop	Polyester	Small
1201HZ7400	Mackworth Hazel Classic Universal Sling with Loop	Polyester	Medium
1201HZ7300	Mackworth Hazel Classic Universal Sling with Loop	Polyester	Large
1201HZ7200	Mackworth Hazel Classic Universal Sling with Loop	Polyester	Extra Large

Mackworth Pine Hammock Sling

Product Code	Description	Material	Size
1201PN7500	Mackworth Pine Hammock Sling with Loop	Polyester	Small
1201PN7400	Mackworth Pine Hammock Sling with Loop	Polyester	Medium
1201PN7300	Mackworth Pine Hammock Sling with Loop	Polyester	Large
1201PN7200	Mackworth Pine Hammock Sling with Loop	Polyester	Extra Large
1201PN750C	Mackworth Pine Hammock Sling with Clip	Polyester	Small
1201PN740C	Mackworth Pine Hammock Sling with Clip	Polyester	Medium
1201PN730C	Mackworth Pine Hammock Sling with Clip	Polyester	Large
1201PN720C	Mackworth Pine Hammock Sling with Clip	Polyester	Extra Large

SLING CODES

mackworth

prismmedicaluk
a prismhealthcare company

Mackworth Willow Toileting Sling

Product Code	Description	Material	Size
1201WL7500	Mackworth Willow Toileting Sling with Loop	Polyester	Small
1201WL7400	Mackworth Willow Toileting Sling with Loop	Polyester	Medium
1201WL7300	Mackworth Willow Toileting Sling with Loop	Polyester	Large
1201WL7200	Mackworth Willow Toileting Sling with Loop	Polyester	Extra Large
1201WL750C	Mackworth Willow Toileting Sling with Clip	Polyester	Small
1201WL740C	Mackworth Willow Toileting Sling with Clip	Polyester	Medium
1201WL730C	Mackworth Willow Toileting Sling with Clip	Polyester	Large
1201WL720C	Mackworth Willow Toileting Sling with Clip	Polyester	Extra Large

Mackworth Maple Stand Aid Back Support Belt

Product Code	Description	Material	Size
1201MP7500	Mackworth Maple Stand Aid Back Support Belt with Loop	Polyester	Small
1201MP7400	Mackworth Maple Stand Aid Back Support Belt with Loop	Polyester	Medium
1201MP7300	Mackworth Maple Stand Aid Back Support Belt with Loop	Polyester	Large
1201MP7200	Mackworth Maple Stand Aid Back Support Belt with Loop	Polyester	Extra Large
1201MP750C	Mackworth Maple Stand Aid Back Support Belt with Clip	Polyester	Small
1201MP740C	Mackworth Maple Stand Aid Back Support Belt with Clip	Polyester	Medium
1201MP730C	Mackworth Maple Stand Aid Back Support Belt with Clip	Polyester	Large
1201MP720C	Mackworth Maple Stand Aid Back Support Belt with Clip	Polyester	Extra Large

Sling Sizing Guide

For help in choosing the correct sling, please refer to the appropriate fitting guide on the [Prism Medical UK website](#).

MACKWORTH ESSENTIALS SATIN SHEETS

mackworth
essentials

prismmedicaluk
a prismhealthcare company

The Mackworth Essentials Satin Sheet range is designed to reduce lifting-associated strains and injuries to caregivers while providing a solution for patients requiring frequent repositioning.

The system consists of two components; a synthetic, breathable satin base sheet with a low friction central section and a soft top sheet with low friction backing. The Mackworth Essentials Satin Sheet range features handles on the top sheet to facilitate more effortless movement and use in conjunction with hoists.

KEY FEATURES & BENEFITS

Base Sheet

- Available in standard and bariatric mattress sizes
- Made of synthetic breathable satin and cotton

Top Sheet

- Maxi (full bed) and Midi (half bed) sizes
- Handles for easier positioning and use with hoists
- Made of synthetic breathable satin and cotton

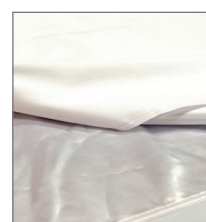

Product Information

Product Code	Description	Dimensions to fit mattress size
2002MAC9020	Mackworth Standard Base Sheet	2000(L)x900(W)mm
2002MAC1420	Mackworth Midi Top Sheet	2000(L)x1400(W)mm
2002MAC12020	Mackworth Satin Sheets Bariatric Base	2000(L)x1200(W)mm
2002MAC2020	Mackworth Satin Sheets Maxi Top	2000(L)x2000(W)mm

FREEWAY BED MANAGEMENT SYSTEM

FREEWAY BODY SUPPORT WEDGE

freeway

prismmedicaluk
a prismhealthcare company

The Freeway Bed Management System (plus-size) provides an easy-to-use, low-friction solution for patients who require frequent repositioning. It consists of two units – a nylon, water-resistant undersheet with wide non-slip sides and a fully breathable, water-resistant, quilted polyester softshell top sheet. The system has been designed to provide comfort for patients and can help to reduce incidences of pressure ulcers. It also provides ease of use by carers and forms an ideal bed solution as part of a single-handed care package.

Also available to work in conjunction with the Freeway Bed Management System is the Freeway Support Wedge. This supports patients in bed and helps them remain in a required position.

KEY FEATURES & BENEFITS

Bed Management System

- Provides comfort for patients
- Minimal effort from carers
- Ideal for use by a single carer
- Works effectively with four-section profiling beds
- It can be used on a pressure care mattress
- It can also be used with a hoist to assist in turning

Body Support Wedge

- Provides a positive non-slip action when used against cotton bed linen
- It can be used to help reduce the incidence of pressure ulcers
- Made from 100% soft and flame-retardant foam
- The polyurethane cover can be machine washed up to 80°C
- The nylon cover can be wiped clean with disinfectant



Product Information

Product Code	Product Description	Dimensions
202ACCBMS-COM	Freeway Bed Management System - Complete - Single Bed Size	-
202ACCBMS-BSS	Freeway Bed Management System - Base Sheet Only	2000(L)x900(W)mm
202ACCBMS-QS	Freeway Bed Management System - Top Sheet Only	2000(L)x1400(W)mm
202ACCBMS-BCOM	Freeway Bed Management System - Complete - Plus Size	-
202ACCBMS-BSB	Freeway Bed Management System - Base Sheet Only - Plus Size	2000(L)x1200(W)mm
202ACCBMS-QB	Freeway Bed Management System - Top Sheet only	2000(L)x1900(W)mm
200FW-WEB53	Freeway Positioning Wedge	53mm(W)
200FW-WEB60B	Freeway Positioning Wedge - Plus Size	60mm(W)

MULTIGLOVE LIMB LIFTER AND SLIDE SHEETS



prismmedicaluk
a prismhealthcare company

The **Prism Multiglove** enables carers to facilitate various moving and handling applications easily due to its low friction. It is a simple but effective piece of equipment. It can be used to bring a person to a sitting position in a profiling bed, as the anti-shear material helps to smooth and release the tension on the skin.

Product Information

Product Code	Description
2002ACCPM-MGLOVE	Prism Multiglove (Pair)



The **Prism Limb Lifter** has been designed to support limbs, allowing many procedures to be completed, i.e. wound care, without the carer having to support the limb. The Prism Limb Lifter can be easily attached to a hoist, enabling the carer to perform procedures in the safest possible working environment, eliminating the possibility of strain or injury from supporting the limb themselves.

Coloured inset loops are featured to aid the correct positioning of the Prism Limb Lifter when attaching to a hoist. Each Prism Limb Lifter is supplied with two removable, washable covers. Additional washable covers can be purchased here.

The product is machine washable up to 72°C.

Product Information

Product Code	Description	Dimensions
2002ACCPLL150X1	Prism Limb Lifter	150mm(L)
2002ACCPLL150X5	Prism Limb Lifter	150mm(L) (box of 5)

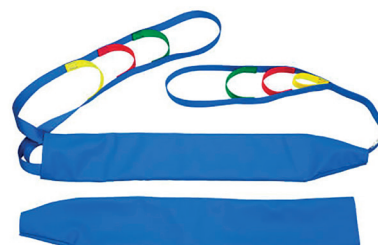

The **Tubular and Flat Slide Sheets** are used as an aid for repositioning and moving patients. Various sizes are available.

Product Information

Product Code	Description
2002ACCPM-MGBROW	Tubular Slide Sheet (720 x 700mm)
2002ACCPM-MGGREY	Tubular Slide Sheet (1100 x 800mm)
2002ACCPM-MGGREE	Tubular Slide Sheet (1350 x 1000mm)
2002ACCPM-FS2	Flat Slide Sheet (2000 x 1000mm)
2002ACCPM-FSH1	Flat Slide Sheet w/ Handles (2000 x 710mm)
2002ACCPM-FSH2	Flat Slide Sheet w/ Handles (2000 x 1000mm)



PRISM ONE-WAY GLIDE PRISM HANDLING BELT



prismmedicaluk
a prismhealthcare company

The **Prism One-Way Glide Sheets** help a patient maintain a good sitting position and allow repositioning on a chair or bed.

The one-way glide will only slide in the direction of the arrows, which are clearly labelled on the sheets. It can be used on all surfaces and helps prevent a patient from sliding forward in a wheelchair/day chair/bed and aids the positioning of a patient into a good sitting position.



Product Information

Product Code	Description
2002ACCPM-OWGS14	Prism One Way Glide - Single 1400 x 430
2002ACCPM-OWGS70	Prism One Way Glide - Single 700 x 430
2002ACCPM-OWGT60	Prism One Way Glide - Tube 600 x 430
2002ACCPM-OWGT73	Prism One Way Glide - Tube 730 x 600

The **Prism Comfi Belt** helps carers perform assisted manoeuvres and transfers safely whilst minimizing the risk of injury to themselves or the user. It has been designed to provide high levels of comfort to the user whilst providing the best possible grip and handling positions for the carer. Available in three sizes, each of which is also adjustable to ensure the perfect fit for waist sizes from 22" (558mm) to 55" (1395mm).

The product is machine washable up to 72°C.



Product Information

Product Code	Description
2002ACCPM-CBLARG	Prism Comfi Belt - Large
2002ACCPM-CBMED	Prism Comfi Belt - Medium
2002ACCPM-CBSMAL	Prism Comfi Belt - Small

SELF PROPEL WHEELCHAIR



harvesthealthcare[®]
a prismhealthcare company

The Self Propel Wheelchair is a cost-effective wheelchair designed around comfort and practicality.

The chair has a robust steel framework and can support a maximum user weight of 110kg.

KEY FEATURES & BENEFITS

- Strong steel framework
- 18 inch wide seat
- Black fire retardant seat material
- PU tyres (no more punctures)
- Rear wheel brakes
- Full-length padded (detachable) armrests
- Armrests are designed to enable the user to sit at tables
- Removable swing-away footrests
- Folding backrest
- Heel support strap
- Optional Anti-wheelie Bars for the rear
- Supplied with instruction booklet and tools

5 year warranty



110kg/17st
max user weight



Product Information

Product Code	Dimensions	Seat	Front Wheel	Rear Wheel	Net Weight
HMS300B	1030 x 650mm	460(Wide)x410(Deep)mm	203mm (8") Diameter	610mm (24") Diameter	18kg

CAR TRANSIT WHEELCHAIR



harvesthealthcare[®]
a prismhealthcare company

The Car Transit Wheelchair is a fantastic economy wheelchair designed around comfort and practicality.

The chair has a robust steel framework and is readily available to assist patients and carers when on the move.

KEY FEATURES & BENEFITS

- Strong steel framework
- 18 inch wide seat
- Black fire retardant seat material
- PU tyres (no more punctures)
- Rear wheel brakes
- Full-length padded (detachable) armrests
- Armrests are designed to enable the user to sit at tables
- Removable swing-away footrests
- Folding backrest
- Heel support strap
- Supplied with instruction booklet and tools

5 year warranty



110kg/17st
max user weight



Product Information

Product Code	Dimensions	Seat	Front Wheel	Rear Wheel	Net Weight
HMA200B	920x600mm	460(Wide)x410(Deep)mm	203mm (8") Diameter	305mm (12") Diameter	15kg

6. SHOWERING AND TOILET AIDS

Prism Healthcare stocks a comprehensive selection of Showering and Toilet Aids suitable for many patients.

FREEWAY ADJUSTABLE HEIGHT SHOWER TROLLEY

freeway

prismmedicaluk
a prismhealthcare company

The Freeway Height Adjustable Shower Trolley benefits from optional cot sides. Its height can be adjusted by the hydraulic foot pump. Available in different sizes of 1500mm, 1700mm and 1900mm, the Freeway Height Adjustable Shower Trolley has a working height between 600mm and 925mm.

The protective coating of all Prism Medical shower trolleys and stretchers includes FREECOTE® - our unique antimicrobial and antibacterial coating, resistant against the hospital superbug MRSA, e-coli, salmonella and listeria.

KEY FEATURES & BENEFITS

- Available in 3 sizes – 1500 mm, 1700 mm and 1900 mm
- Has a working height of 600 mm to 925 mm
- Practical ergonomic design
- Durable, manoeuvrable and extraordinary value for money.
- Top quality stainless steel bearing castors
- Special custom build available
- Includes FREECOTE® – our unique antimicrobial and antibacterial coating

5 year warranty



200kg/30st
max user weight



With Adjustable Backrest



Padded Changing Trolley



With Liner

Product Information

Product Code	Product Description
1801AHT1900	Adjustable Height Trolley - 1900mm
1801AHT1700	Adjustable Height Trolley - 1700mm
1801AHT1500	Adjustable Height Trolley - 1500mm
1801AHT1900B	Adjustable Height Trolley with Adjustable Backrest - 1900mm
1801AHT1700B	Adjustable Height Trolley with Adjustable Backrest - 1700mm
1801AHT1500B	Adjustable Height Trolley with Adjustable Backrest - 1500mm
1801AHTPC1900	Adjustable Height Padded Changing Trolley - 1900mm
1801AHTPC1700	Adjustable Height Padded Changing Trolley - 1700mm
1801AHTPC1500	Adjustable Height Padded Changing Trolley - 1500mm
1801AHT1900L	Adjustable Height Trolley with Liner - 1900mm
1801AHT1700L	Adjustable Height Trolley with Liner - 1700mm
1801AHT1500L	Adjustable Height Trolley with Liner - 1500mm

OPTIONAL EXTRAS:

- Cotside in 3 different lengths 1300mm; 1802ACCWCU13, 1500mm; 1802ACCWCU15 and 1700mm; 1802ACCWCU17
- Padding for Cotside; 1802ACCWCP
- Padded Wedged Pillow; 1802ACCPADWTP

MACKWORTH TILT IN SPACE SHOWER CHAIR

mackworth

prismmedicaluk
a prismhealthcare company

The Mackworth M80 shower chair provides comfort and dignity for patients during washing and toileting routines while maintaining ease of use for the carer.

It provides a versatile bathing and toileting solution for various patients.

KEY FEATURES & BENEFITS

- Tilt-in-space shower/commode chair
- Adjustable seat angle of 6° to 25° ensures suitability for a wide range of conditions and facilitates patient transfers
- Length adjustable, swing-away footrest for ease of access and for varying leg lengths
- Height adjustable headrest suitable for a range of patient heights
- Flip-up armrests manufactured in robust yet lightweight aluminium
- Durable and easy to transport; will not rust or corrode in wet environments
- A padded seat provides a comfortable and secure seating position for the patient
- 4 individually locking castors provide a stable seating position whilst aiding manoeuvrability
- The removable backrest can be laundered and replaced as necessary

5 year warranty



158kg/25st
max user weight



Dimensions

Overall Width	650mm	Seat Width	450mm	Back Height From Seat	1000mm
Overall Height	1100-1400mm	Seat Height	550mm	Armrest Height From Seat	250mm
Overall Length	1000mm	Seat Depth	420mm	Armrest Width x Armrest Length	50 x 240mm

Product Information

Product Code	Description
1601M80	Aluminium Tilt Transit Shower / Commode Chair

FREEWAY ASSISTED OR SELF-PROPELLED SHOWER, TOILET AND COMMODE CHAIRS

freeway

prismmedicaluk
a prismhealthcare company

Manufactured in the UK from only the highest quality materials, the comprehensive range of Freeway assisted or self-propelled shower, toilet and commode chairs are pioneering and firmly established as having a reputation second to none.

High-quality, robust and durable, they are designed to provide the most effective solution to a client's toileting and showering needs.

Freeway Shower Chairs are modular, which means they can be configured to a choice of interchangeable seats, backrests, armrests and footrests.

Many accessories are available to meet individual requirements and ensure the most bespoke solution.

All adult models within the range are specifically designed to fit over a standard toilet or commode, with three widths available:

A – 540 mm (21")

B – 490 mm (19")

C – 440 mm (17")

Paediatric, plus size and models to fit over automatic toilets are also included in the range.

The interchangeable makeup of Freeway Shower Chairs makes the range the most adaptable solution on the market, as accessories and parts can be added to suit a client's changing needs.

Chairs can be manufactured with frames to be lowered and raised, rear wheels set back/forward and the frame depth extended and shortened.

Prism Medical UK has a team of experienced Assessors who can carry out a comprehensive shower chair assessment to determine the needs of the individual. To ensure the most effective and supportive solution to meet your patient's needs, we highly recommend a shower chair assessment is made before purchase.

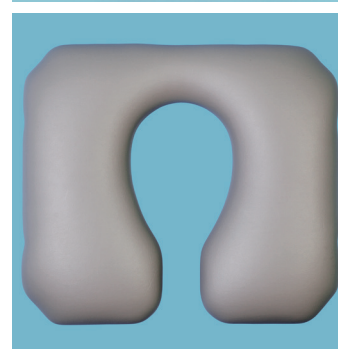
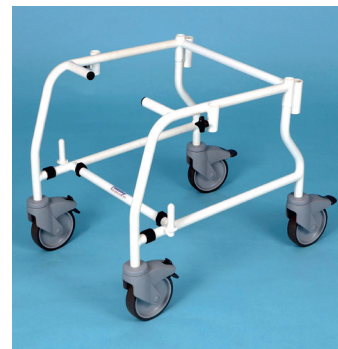

FREEWAY HEIGHT ADJUSTABLE SHOWER COMMODE CHAIR

freeway

prismmedicaluk
a prismhealthcare company

With its modular design, the Freeway Height Adjustable shower chair is a highly versatile assistant-propelled shower, toilet or commode chair available in various widths. The chair's seat height can be adjusted from 510mm to 560mm in 25mm increments.

The design features anti-tangle swivel castors, which provide a smoother ride for the user and include an obvious red brake lever making it easy to see if the brake has been applied. The castor design also prevents the build-up of dirt and hair, ensuring the wheels don't become blocked and reducing the need for ongoing maintenance.

KEY FEATURES & BENEFITS

- Height adjustment makes it easier to use with toilets of varying sizes
- High-quality chair manufactured in the UK from UK-sourced materials
- Built to last, robot-welded steel frame and non-rust components
- Service-free, anti-tangle castors prevent dirt and hair from clogging the wheels
- Modular design allows for total configuration to suit the client's needs
- Cost-effective, as parts can be easily added or changed
- A variety of seat options ensure maximum comfort for the user
- Includes FREECOTE® – our unique antimicrobial and antibacterial coating

5 year warranty



200kg/30st
max user weight



Dimensions/Technical Information

Overall maximum height	980mm
Overall maximum width	560 - 640mm
Width of a standard seat	440/490/540mm
Height to the top of the seat	510 - 560mm
Height clearance	445mm (at full height)

Product Information

Description	Full chair product code	Frame only product code
Freeway Height Adjustable A (540mm wide)	1601FWHAA	1602CHFAA
Freeway Height Adjustable B (490mm wide)	1601FWHAB	1602CHFAB
Freeway Height Adjustable C (440mm wide)	1601FWHAV	1602CHFAC

FREEWAY T80 RECLINING SHOWER CHAIR



The Freeway T80 Shower Chair is highly versatile, and the reclined position has significant advantages for increasing comfort and relieving pressure for a wide range of conditions, including:

- Multiple Sclerosis
- Spinal injuries
- Motor Neurone Disease
- Stroke and other neurological conditions
- Cerebral Palsy

It has two variations; Freeway T80 COM and Freeway T80 AUTO.

Freeway T80 COM: A variation of the T80 reclining shower chair designed to work seamlessly with the Clos-o-Mat Samoa toilet.

T80 AUTO: A standard T80 modified for use with automatic toilets, including the Mera, Geberit range and Clos-o-Mat Palma Vita.

KEY FEATURES & BENEFITS

- This chair reclines through infinite positions up to 40 degrees and is easy to operate
- A wide range of positioning accessories is available
- The tilt action is easy and light to use and features two high-quality, stainless steel gas struts
- Available as assistant-propelled or self-propelled

5 year warranty



Freeway T80 COM



Freeway T80 AUTO

Product Information

Product Code	Description
1601T80C	T80 Tilt-in-Space Shower Chair – 440mm wide
1601T80B	T80 Tilt-in-Space Shower Chair – 490mm wide
1601T80A	T80 Tilt-in-Space Shower Chair – 540mm wide

FREEWAY T70 SHOWER CHAIR

freeway

prismmedicaluk
a prismhealthcare company

The Freeway T70 Shower Chair is available as a shower, toilet or commode chair. One of the significant benefits of the Freeway T70 is that it is fitted with large-braked rear wheels and push rims making this chair extremely easy to self-propel.

As with all Freeway Shower Chairs, only the finest materials have been used during manufacturing to ensure the shower chair is durable and long-lasting.

The Freeway T70 offers the ultimate hygiene, as the durable seat, backrest, and armrests can be wiped down after use. The protective coating of the shower chair includes FREECOTE® – our unique antimicrobial and antibacterial coating, which is resistant to the hospital superbug MRSA, e-coli, salmonella and listeria.

KEY FEATURES & BENEFITS

- Available as a shower, toilet or commode chair
- Versions available to fit over Clos-o-Mat toilets, automatic bidets and for those who require easy side access
- Perfect for those who require a chair that is extremely easy to self propel
- Puncture-proof rear braked wheels with removable push rims
- Large diameter castors to the front allow easy manoeuvring over uneven surfaces
- Frame constructed from heavy-duty, durable tubing to provide years of rust-free performance
- Pliable backrest moulds to the user while providing excellent support
- Durable seat, backrest and armrests can be easily wiped clean to ensure superior levels of hygiene
- The coating of the shower chair frame includes FREECOTE®, our unique antibacterial and antimicrobial coating

5 year warranty



200kg/30st
max user weight



Product Information

Product Code	Description
1601T70C	Self propelled Shower/Toilet/Commode Chair – 440mm wide
1601T70B	Self propelled Shower/Toilet/Commode Chair – 490mm wide
1601T70A	Self propelled Shower/Toilet/Commode Chair – 540mm wide

FREEWAY T40 ASSISTANT PROPELLED SHOWER CHAIR

freeway

prismmedicaluk
a prismhealthcare company

The Freeway T40 is a highly versatile assistant-propelled shower, toilet or commode chair. The chair has many applications and can be easily raised/lowered or extended forward. The rear castors can be set back for amputee use.

KEY FEATURES & BENEFITS

- A highly versatile shower chair with bespoke options for a variety of applications
- Versions available to fit over Clos-o-Mat toilets and other automatic bidets
- Heavy-duty total stop castors and footrests fitted as standard
- Frame constructed from heavy-duty, durable tubing to provide years of rust-free performance
- Durable seat, backrest and armrests can be easily wiped clean to ensure excellent levels of hygiene
- The coating of the shower chair frame includes FREECOTE®, our unique antibacterial and antimicrobial coating.

5 year warranty



200kg/30st
max user weight



Product Information

Product Code	Description
1601T40C	T40 Assistant Propelled Shower Chair – 440mm wide
1601T40B	T40 Assistant Propelled Shower Chair – 490mm wide
1601T40A	T40 Assistant Propelled Shower Chair – 540mm wide

ELEXO SHOWER CHAIR



harvesthealthcare
a prismhealthcare company

The Elexo is a height-adjustable shower-toilet chair providing comfort and security for carers and patients. Built for safety, comfort and cleanliness, the Elexo is an exceptional tool for carers looking to give residents a secure and calm showering or toileting experience.

KEY FEATURES & BENEFITS

- Simple electric height adjustment
- Hand control with battery indicator
- Sleep mode setting after 60 minutes
- Tilt adjustment to a maximum of 17 degrees
- Easy clean, hygienic seat with toilet opening
- Inlay for the toilet opening
- Foldable upholstered armrests with the front lock to enable sideways transfer
- Ergonomically formed seat and backrests
- Fold-out footrests with calf protection
- Fold-away and removable leg supports
- Rail for toilet bucket or bedpan
- Durable castors with swivel & lock features
- Extremely stable due to the fitting of two lifting motors
- Simple to recharge, with charger included

3 year warranty



180kg/28st
max user weight



**Ergonomically
formed seat for
toilet use**

Product Information

Product Code	Seat Width	Seat Depth	Adjustable Height
HLA013	480mm	460mm	50m-105mm

EVE

SHOWER AND BATH LIFTER



harvesthealthcare[®]
a prismhealthcare company

The sleek Eve Shower and Bath Lifter allows users to safely and comfortably shower or bathe. Highly manoeuvrable and fitting in most modern care bathtubs, the Eve is suitable for residents who need extra support getting in and out of the bath and is also fully functional as a shower chair.

KEY FEATURES & BENEFITS

- Made entirely of aluminium and stainless steel
- 100% functional as a shower chair
- Simple operation by only one carer
- Unrestricted transfer from the Ascent Pro 200 to the seat lifter
- Ergonomically designed safety steering handles ensure accurate manoeuvring
- Easy-to-maneuver double castors
- Handheld control unit with a visual indication of battery level
- The integrated service module reports technical problems with the lift and necessary maintenance.

3 year warranty



185kg/29st
max user weight



OPTIONAL EXTRAS:

- Digital scale
- Replacement battery
- External wall charging station

Product Information

Product Code	Length	Width	Height	Lifting Range	Free Space Under Carrier Frame
HLA008	950mm	680mm	1240mm	495mm-1065mm	30mm

7. EVACUATION PRODUCTS

The range of Evacuation Products from Harvest Healthcare is designed to be used in an emergency. Patients will be kept secure and comfortable during an evacuation if the appropriate equipment is used correctly. For more information, don't hesitate to get in touch with a member of the sales team.

EVACUATION SHEET

EVACUATION SLEDGE



EVACUATION SHEET

The Fire Evacuation Sheet is designed to be used with standard foam mattresses. This sheet features a silicone-coated side to aid the swift and easy movement of the device across all surface types. During an evacuation, the straps are secured around the mattress, and the patient is then evacuated to safety.

The red polyester fabric is Fire Retardant, extremely strong, and has been vigorously tested.



Product Information

Product Code	Description
HTE001	Evacuation Sheet

EVACUATION SLEDGE

The Evacuation Sledge fits underneath the existing active mattress and is designed to suit most mattresses.

It contains a high-density foam base so that in the event of an evacuation, the air mattress can be deflated by opening the CPR valves and disconnecting from the pump.

The patient is then securely strapped in and evacuated to safety.

The mattress base has a section of low-friction material to make it easier to pull on most surfaces.

Easily accessible emergency straps are hidden in pockets to prevent fouling profiling bed mechanisms.



Product Information

Product Code	Description
HTE008	Evacuation Sledge for Active Mattresses

EVACUATION MATTRESSES



EVACUATION SHEET FOR ACTIVE MATTRESSES

This Evacuation Sheet is designed to take an active air mattress. In an evacuation, the service user is secured to the mattress using the straps on the evacuation sheet and moved to safety along with the mattress. Suitable for both Replacement and Overlay mattresses. The red polyester fabric is Fire Retardant, extremely strong and has been vigorously tested.



Product Information

Product Code	Description
HTE001.2	Evacuation Sheet for Active Mattresses

WALL MOUNTED EVACUATION MATTRESS WITH STORAGE BAG

The Wall Mounted Evacuation Mattress includes a 50mm foam base to support the patient during evacuation. During evacuation, the patient is placed on the mattress, secured using the straps provided and evacuated to safety. This popular product includes a storage bag and is designed to be mounted on a wall until needed.

The red polyester fabric is Fire Retardant, extremely strong and has been vigorously tested.



Product Information

Product Code	Description
HTE002	Wall Mounted Evacuation Mattress with Storage Bag

STAIRWAY EVACUATION



EMERGENCY STAIRWAY EVACUATION DEVICES

Regulations require that your emergency plan should be appropriate for your premises, and arrangements should be in place for the safe evacuation of people who are especially at risk. With these unique chairs, evacuations can be carried out by only one person, giving you a better chance of getting your patients out in time. These chairs can fold down for easy storage and include wall mounting brackets.

EXITMASTER EGO

The Exitmaster Ego is easy to use and is ultra-slim for storage. It has two wheels with auto brakes when folded. It provides a comfortable and supportive seat position and includes a wall mounting bracket. The safe working load is 150kg / 24 Stone.

Product Information

Product Code	Description
HTE202	Exitmaster Ego



EXITMASTER VERSA

The Exitmaster Versa has a 4 wheel design, meaning it travels well on landings, corridors and stairs. It has safety brakes on the rear wheels and includes a wall mounting bracket. The seat offers excellent support and comfort and aids easy transfer with an advanced belt guide system. There is also a footrest for comfort. The safe working load is 150kg / 24 Stone.

Product Information

Product Code	Description
HTE200	Exitmaster Versa



EXITMASTER ELITE

The Exitmaster Elite has a 4 wheeled design, meaning it travels well on landings, corridors and stairs. This Exitmaster provides extra comfort with a padded seat, armrests and an advanced headrest with a headband. It also has a footrest. There is an integral 4-point harness and a wall mounting bracket. This stairway evacuation device can double as a transit chair.

The safe working load is 150kg / 24 Stone.

Product Information

Product Code	Description
HTE201	Exitmaster Elite



8. REPOSE SPECIALIST SEATING

In January 2021, Repose Furniture Ltd was acquired by the Prism Healthcare Group and became a sister company to Harvest Healthcare.

Repose is one of the market leaders in specialist seating solutions, designing and manufacturing a full range of specialist chairs ranging from entry-level riser-recliners to advanced bespoke healthcare chairs.

This acquisition allows Harvest to add the supply and service of specialist seating alongside our current range of beds, pressure care and moving & handling equipment.

All Repose chairs are manufactured in our own factory in the West Midlands. This ensures you receive the highest standards of quality, short lead times and bespoke manufacture to meet your needs.

In this section, you will find the following:

Georgia Basic Recliner Chair

Lynton Riser Recliner Chair

Multi C-air Riser Recliner Chair

Multi Flex Chair Porter Chair

Madison Riser Porter Chair

Boston Porter Chair

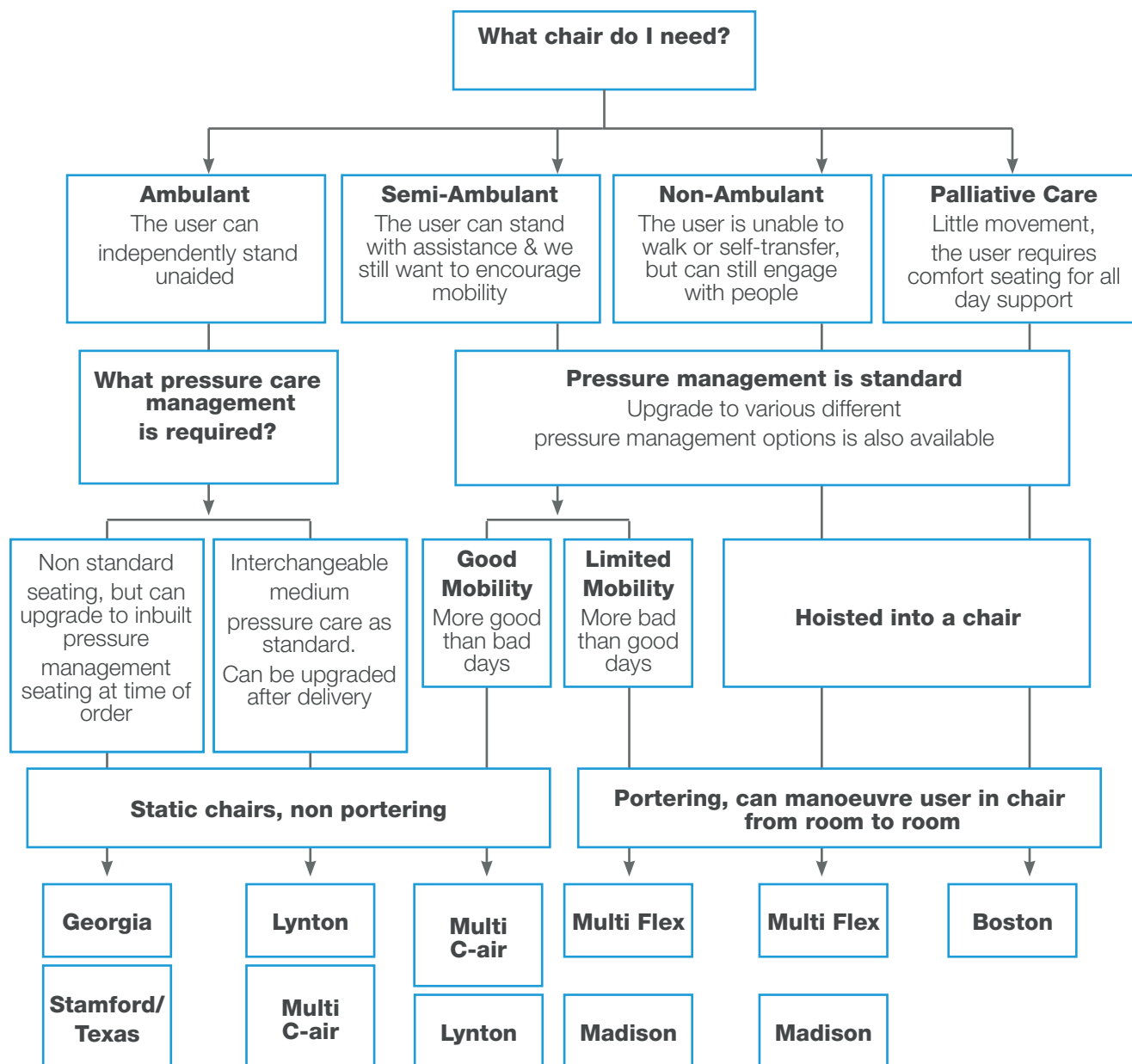

To find out more information about the different seating solutions please visit the Repose website:

www.reposefurniture.com

GEORGIA BASIC RECLINER CHAIR



This chair is designed for general comfort, with limited seams and simple lines for infection control. It is ideal for bedside seating in care homes, hospital wards, day units and hospices. The Georgia is suitable for ambulant and semi-ambulant users who require little assistance using the rise feature on these chairs. However, it is unsuitable for non-ambulant users.

Mechanism Movements:

- Manual recline only – users with good mobility and strength
- Electric recline only – users with reduced mobility but who can stand unassisted
- Electric recline and rise – users with reduced mobility who require assistance to stand

The chair is available in Vinyl fabrics as standard.

KEY FEATURES & BENEFITS

- Fixed back cushion style
- Crib 5 Healthcare fabric, easy to clean
- One standard size
- Various mechanism movements
- No pressure care seating
- Limited seams for infection control
- The maximum weight limit can be upgraded to 158kg / 25 stone

2 year warranty

127kg/20st
weight limit



Stamford Chair
(Wingless Georgia)



Texas Chair
(Georgia with Supportive
Cushions)

Product Size Information

Seat Height	480mm (19")
Seat Width	510mm (20")
Seat Depth	510mm (20")
Back Height	710/740mm (28/28")
Arm Height	180mm (7")
Overall Height	1140mm (45")
Overall Width	760mm (30")

Optional Extras

- Magnetic handset storage to side of arm
- Medium to high pressure care seating inclusive of Dartex fabric to seat
- Full length arm cap protectors
- Drop down side table (not available on risers)
- Wall mounted transformer
- USB charger point to outside arm
- Supportive head cushions
- Supportive back cushions

MULTI C-AIR RISER RECLINER CHAIR



The Multi C-Air has been designed for use in domiciliary homes, loan stores, discharge support environments, and nursing and residential homes. With interchangeable pressure management and posture support, the chair is suitable for ambulant and semi-ambulant users who require a little assistance using the rise feature on these chairs. It is unsuitable for non-ambulant users.

Mechanism Movements:

- Single tilt in space recline and rise – users with reduced mobility who require assistance to stand
- Dual electric recline and rise – users with reduced mobility who require assistance to stand

Fabric Options:

- Standard fabric available is Vinyl; other fabrics are also available to suit the user's environment
- Dartex as standard

KEY FEATURES & BENEFITS

- Removable/interchangeable back posture support
- Interchangeable low-pressure management
- Crib 5 Healthcare fabric, or any design to suit the setting, easy to clean
- 6 standard sizes from small to large
- Seat height adjustable, lockable castor optional
- Dartex seat and leg fabric as standard

2 year warranty

127kg/20st
weight limit



Product Size Information

	Small	Medium	Large
Seat Height	406mm (16")	457mm (18")	508mm (20")
Seat Width	457mm (18")	508mm (20")	559mm (22")
Seat Depth	457mm (18")	508mm (20")	508mm (20")
Seat Height <small>Fitting 50mm Leg adjuster</small>	457mm (18")	508mm (20")	559mm (22")
Depth Height <small>Fitting 50mm Seat Depth Pad</small>	406mm (16")	457mm (18")	457mm (18")
Back Height	711mm / 737mm (28" / 29")		
Arm Height	178mm (7")		

Optional Extras

- High pressure care seating inclusive of Dartex fabric to seat
- Wall mounted transformer
- Full length arm cap protectors
- Supportive head cushions
- Reading lamp
- Accupak alarm wireless chair system
- Various posture support back options

MULTI FLEX PORTER CHAIR



The Multi Flex chair is ideal for nursing and residential home, domiciliary and hospital ward environments. The chair is suitable to reduce manual handling for semi-ambulant and non-ambulant users who require daytime portering in a seated position with interchangeable pressure management and posture support. However, the Multi Flex is not suitable for those who need palliative care.

Mechanism Movements:

- 3 positions, ramped seat angle, to reduce risk of slipping, independent backrest recline

Fabric Options:

- Standard fabric available is Vinyl; other fabrics are also available to suit the user's environment
- Dartex as standard

KEY FEATURES & BENEFITS

- Removable/interchangeable back posture support
- Interchangeable seat low-pressure management
- Adjustable seat angle for secure seating 10°-20°
- Manual back recliner
- Crib 5 Healthcare fabric, or any design to suit the setting, easy to clean
- 3 standard sizes from small to large
- Dartex seat and back fabric
- Sliding footplate, push handle and heavy-duty lockable castors

2 year warranty

127kg/20st
weight limit



Product Size Information

	Small	Medium	Large
Seat Height	410mm (16")	460mm (18")	510mm (20")
Seat Width	410mm (16")	460mm (18")	510mm (20")
Seat Depth	410-533mm (16"-21")	410-533mm (16"-21")	410-533mm (16"-21")
Overall Width	700mm (28")	750mm (29.5")	800mm (31.5")
Overall Depth	810mm (32")	810mm (32")	810mm (32")
Overall Height	960mm (38")	1010mm (40")	1070mm (42")

Optional Extras

- Leg support block
- Connecting straps for leg support block
- Supportive head cushions
- Medium to High pressure care seating inclusive of Dartex fabric to seat

MADISON RISER PORTER CHAIR



The Madison is ideal for nursing and residential home, domiciliary, hospital wards and day unit environments. The chair is suitable to reduce manual handling for semi-ambulant and non-ambulant users who require daytime portering in a seated position with interchangeable pressure management and posture support. It is ideal for encouraging client independence when possible. However, the Madison is not suitable for those who need palliative care.

Mechanism Movements:

- Dual electric recline and rise – users with reduced mobility who require assistance to stand

Fabric Options:

- Standard fabric available is Vinyl; other fabrics are also available to suit the user's environment
- Dartex as standard

KEY FEATURES & BENEFITS

- Removable/interchangeable back posture support
- Interchangeable low-pressure management
- Electrically operated with rise function
- Crib 5 Healthcare fabric, or any design to suit the setting, easy to clean
- 3 standard sizes from small to large
- Dartex seat and back as standard
- Push handle and heavy-duty lockable castors
- Loop for handset storage

2 year warranty

127kg/20st weight limit



Product Size Information

	Small	Medium
Seat Height	483mm (19")	483mm (19")
Seat Width	470mm (18.5")	521mm (20.5")
Seat Depth	508mm (20")	508mm (20")

Optional Extras

- Sliding footplate
- Supportive head cushions
- Accupak rechargeable wireless battery alarm system
- Removable wireless charging table
- Reading light
- USB charger
- Full length arm protector covers
- Magnet storage handset

BOSTON PORTER CHAIR



The Boston Porter chair is ideal for nursing and residential homes, domiciliary, hospital wards, day units and hospice environments. The chair is suitable to reduce manual handling for non-ambulant users and palliative care patients who require daytime portering in a seated position with interchangeable pressure management and posture support. It is also ideal for users with long-term seating requirements as it can help them to change their environment and reduce bed use. However, the chair is not suitable for ambulant and semi-ambulant users.

Mechanism Movements:

- Manual or electric tilt in space, leg rest and back recline.

Fabric Options:

- Standard fabric available is Vinyl; other fabrics are also available to suit the user's environment
- Dartex as standard

KEY FEATURES & BENEFITS

- Removable/interchangeable back posture support
- Interchangeable low-pressure management
- Manual independent tilt in space, leg rest and back recliner
- Crib 5 Healthcare fabric, or any design to suit the setting, easy to clean
- D-rings for the use of optional extras, i.e. lap strap
- Dartex fabric as standard
- Push handle and heavy-duty lockable castors
- Wing push handles
- Rear notes pocket

2 year warranty

127kg/20st weight limit



Product Size Information

	Small	Medium	Large
Seat Height	635mm (25")	635mm (25")	635mm (25")
Seat Width	457mm (18")	508mm (20")	559mm (22")
Seat Depth	508mm (20")	508mm (20")	508mm (20")
Arm Height	178mm (7")	178mm (7")	178mm (7")
Overall Height	1270mm (50")	1270mm (50")	1270mm (50")
Overall Seat Width	699mm (27.5")	749mm (29.5")	800mm (31.5")
Overall Depth	927mm (36.5")	927mm (36.5")	927mm (36.5")

Optional Extras

- Height/angle adjustable footplate
- Electric option available
- Sliding footplate
- Supportive head cushions
- Full length arm protector covers
- Full length arm protector with width adjustment
- Back support posture control wedges
- Footplate pads

prismhealthcare



prismmedicaluk
a prismhealthcare company

prismmedicalscotland
a prismhealthcare company

Formerly Assured Healthcare



www.harvesthealthcare.co.uk

Email: sales@harvesthealthcare.co.uk

Tel: 01709 377172

Harvest Healthcare is a leading manufacturer and supplier of quality healthcare equipment. Specialised in manufacturing and distributing pressure care equipment, they continually develop their product range to deliver complete solutions for all modern care environments.



www.reposefurniture.com

Email: info@reposefurniture.com

Tel: 01384 567401

For over 20 years, Repose has designed and manufactured bespoke healthcare and riser recliner chairs for all care environments.



www.smirthwaite.co.uk

Email: info@smirthwaite.co.uk

Tel: 01626 835552

Smirthwaite have been designing, manufacturing and selling equipment for children and young people with special needs since 1986.



www.prismmedical.co.uk

Email: info@prismmedical.co.uk

Tel: 01924 840100

Prism Medical UK provides moving, handling and bathing products for a variety of client needs, with cost-effective solutions for tight budgets available from Mackworth, and premium options available through Freeway as required.



Formerly Assured Healthcare

www.assured.co.uk

Email: info@assured-hs.co.uk

Tel: 01786 478390

Prism Medical Scotland (formerly known as Assured Healthcare (Scotland) Ltd) is an established and trusted supplier to the healthcare sector with over 20 years experience in the installation of patient lifting and bathing equipment.

prismhealthcare



Unit 4, Jubilee Business Park, Jubilee Way,
Grange Moor, Wakefield, WF4 4TD
T +44 (0)1924 840100
E info@prismmedical.co.uk

www.prismhealthcare.co.uk

